



TOWN OF OCEAN CITY

The White Marlin Capital of the World

MAYOR
RICHARD W. MEEHAN

CITY COUNCIL

MATTHEW M. JAMES
President

ANTHONY J. DELUCA
Secretary

PETER S. BUAS
JOHN F. GEHRIG, JR.
J. FRANKLIN KNIGHT
LLOYD MARTIN
MARK L. PADDACK

CITY MANAGER
TERRANCE J. MCGEAN

CITY CLERK
DIANA L. CHAVIS, CMC

ADDENDUM # 1: OC Lifesaving Museum Elevator

Date of Addendum: 6/24/24

NOTICE TO ALL BIDDERS AND PLANHOLDERS

The Bid Documents for the above-referenced Project are modified as set forth in this Addendum. The original Bid Documents and any previously issued addenda remain in full force and effect, except as modified by this Addendum, which is hereby made part of the Bid Documents. Vendors will take this Addendum into consideration when preparing and submitting a bid, and will acknowledge receipt of this Addendum in the space provided in the Bid Documents.

BID SUBMITTAL DEADLINE

The bid submittal time has not been changed.

1.0 – QUESTIONS AND ANSWERS

The following questions and answers are provided as a matter of information to clarify issues raised about the Bid Documents.

Item	Questions and Answers
1.1	The last day for questions has been extended to Wednesday, July 17, 2024.

www.oceancitymd.gov

P.O. BOX 158 • OCEAN CITY, MARYLAND • 21843-0158

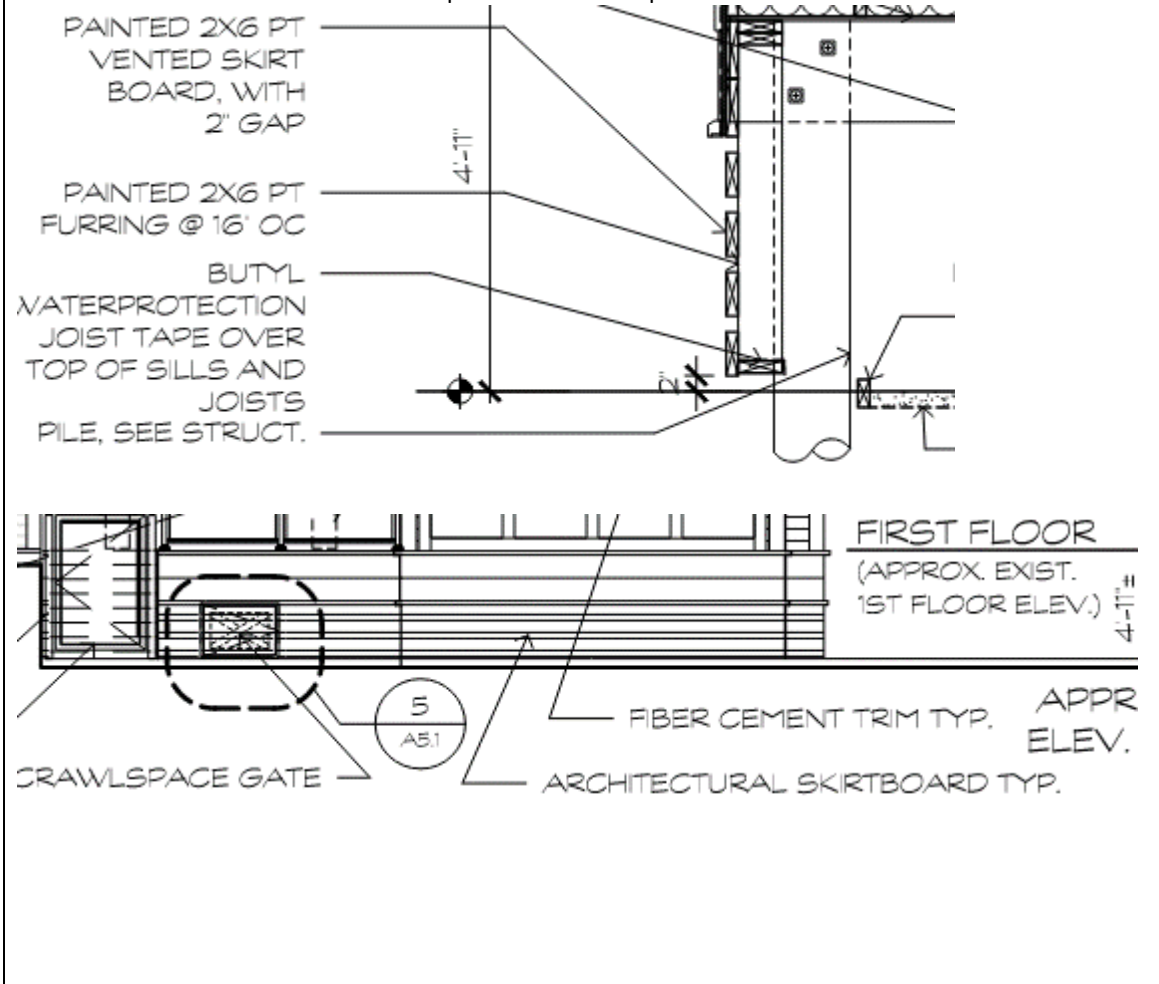

City Hall – (410) 289-8221 • FAX – (410) 289-8703

1.9	What load will be applied to the 3-ply girder truss shown on the second-floor framing plan of S1.2?
2.0	Could the 3-ply girder truss shown on the second-floor framing plan of S1.2 be substituted for an alternative structural member? Please advise.
2.1	On drawing M2.1 they show a ESP-1 sump pump and say to refer to drawing M-3.1, but there is no reference to it there. Could you provide the specifications for the pump including a piping detail?
2.2	Are equivalent substitutions by Daiken or Samsung for the ductless splits allowed, or do they have to be manufactured by Trane?
2.3	ATTACHMENTS FROM DYLAN NEPERT SENT TO SWAGNER ON 6-17-24
2.4	<p>Referencing sheet A4.1 and A2.1. On A4.1 you state it is pressure treated skirt board and A2 you state that it architectural skirt board. Would you like the skirt board and furring strips to be actually manufactured out of an Azek or similar product? It will help with the coastal look.</p>  <p>PAINTED 2X6 PT VENTED SKIRT BOARD, WITH 2" GAP</p> <p>PAINTED 2X6 PT FURRING @ 16' OC</p> <p>BUTYL WATERPROTECTION JOIST TAPE OVER TOP OF SILLS AND JOISTS</p> <p>PILE, SEE STRUCT.</p> <p>4'-11"</p> <p>FIRST FLOOR (APPROX. EXIST. 1ST FLOOR ELEV.) 4'-11"</p> <p>5 A5.1</p> <p>CRAWLSPACE GATE</p> <p>FIBER CEMENT TRIM TYP. APPR ELEV.</p> <p>ARCHITECTURAL SKIRTBOARD TYP.</p>
2.5	Referencing sheet A8.1, is there a basis of design you would like for the white bead board?
2.6	Referencing the bid documents, is there any way we can negotiate the liquidated damages with the town? To be specific, have LD's not apply to items that are outside of our specified time frame. We could do this after we are given a letter of intent and investigate further the lead times of certain items we know are always an issue and we could negotiate the items in to the contract but still have LD's applied to other areas of the contract.
2.7	After reviewing the scope of work and special conditions portions of the contract, is wage scale applicable to this project? This is a courtesy question to the owner as it is usually stated whether or not it is or isn't.

www.oceancitymd.gov

P.O. BOX 158 • OCEAN CITY, MARYLAND • 21843-0158



City Hall – (410) 289-8221 • FAX – (410) 289-8703

2001

END OF ADDENDUM

www.oceancitymd.gov

P.O. BOX 158 • OCEAN CITY, MARYLAND • 21843-0158



City Hall – (410) 289-8221 • FAX – (410) 289-8703

2001