

# TOWN OF OCEAN CITY, MARYLAND



PROCUREMENT DEPARTMENT

## BID DOCUMENT FOR

### Eagle's Landing Cart Bridge Renovations

---

<b>BID TIMELINE OF EVENTS</b>
<b>Pre-Bid Meeting:</b> Thursday, September 12, 2019 at 10:00am at Eagle's Landing Golf Course in the Club House located at 12367 Eagle's Nest Road, Berlin, MD 21811
<b>Last Day for Questions:</b> Noon on Friday, September 17, 2019
<b>Addendum:</b> Close Of Business on Monday September 23, 2019
<b>Bid Due Date, Time, &amp; Location:</b> Monday, September 30, 2019 at 4:00pm sent to Town of Ocean City, Maryland Attn: City Manager; Room 230, 301 N. Baltimore Avenue, Ocean City, MD 21842
<b>Bid Opening Date, Time, &amp; Location:</b> Tuesday, October 01, 2019 at 1:00pm in Council Chambers located at 301 N. Baltimore Avenue, Ocean City, MD 21842
<b>Ad Run:</b> Thursday, August 15, 2019

SECTION I: INTRODUCTION .....	4
1. PURPOSE .....	4
2. CLARIFICATION OF TERMS .....	4
3. QUESTIONS AND INQUIRIES .....	4
4. FILLING OUT BID DOCUMENTS .....	4
5. SUBMISSION OF BID DOCUMENTS .....	4
6. OPENING OF BID DOCUMENTS .....	5
7. ACCEPTANCE OR REJECTION OF BID DOCUMENTS .....	5
8. NOTICE TO VENDORS .....	6
9. PRE-BID MEETING .....	6
SECTION II: GENERAL INFORMATION .....	7
1. ECONOMY OF BID DOCUMENTS .....	7
2. RESPONSIBILITIES OF THE VENDOR .....	7
3. PROPRIETARY INFORMATION OR TRADE SECRETS .....	7
4. OWNERSHIP OF MATERIALS .....	7
5. CONTRACT AWARD .....	7
7. AUDIT .....	8
8. NONPERFORMANCE .....	8
9. MODIFICATION OR WITHDRAWAL OF BID DOCUMENTS .....	8
10. DEFAULT .....	8
11. COLLUSION/FINANCIAL BENEFIT .....	8
12. TAX EXEMPTION .....	8
13. EQUAL EMPLOYMENT OPPORTUNITY AND NON-DISCRIMINATION .....	9
14. STATUS OF VENDOR .....	9
15. APPLICABLE LAWS .....	9
16. SUSPENSION OR TERMINATION FOR CONVENIENCE .....	9
17. TERMINATION FOR CAUSE .....	10
18. ADDENDUM .....	10
19. INSURANCE REQUIREMENTS .....	10
20. ASSIGNMENTS .....	11
21. INDEMNIFICATION .....	11
22. SUBCONTRACTING .....	11
23. CONTRACT CHANGES .....	12
24. AVAILABILITY OF FUNDING .....	12
25. FORCE MAJEURE .....	12
26. PROTESTS .....	12
27. FEDERAL TAX IDENTIFICATION NUMBER .....	12
28. BID RESULTS .....	12
29. CONFORMANCE TO BID REQUIREMENTS .....	12
30. PRODUCT IDENTIFICATION .....	13
31. PAYMENT .....	13
32. INVESTIGATION OF REFERENCES AND CONSIDERATION OF PAST PERFORMANCES .....	13
33. BIDS ARE OFFERS .....	13
34. CONTINGENT BIDS .....	13
35. REPRESENTATIONS AND WARRANTIES .....	13
36. CONFLICT OF INTEREST .....	13
37. WARRANTIES .....	13
38. NO THIRD PARTY BENEFICIARIES .....	14
39. TIME IS OF THE ESSENCE .....	14
40. FOREIGN VENDOR .....	14
41. ATTACHMENTS .....	14
42. MERGER .....	14
SECTION III: GENERAL CONDITIONS .....	16
1. DEFINITIONS .....	16
2. MATERIALS, SERVICES AND FACILITIES .....	16
3. INSPECTION AND TESTING .....	17
4. SURVEYS, PERMITS, REGULATIONS .....	17
5. PROTECTION OF WORK, PROPERTY AND PERSONS .....	17

6.	SUPERVISION BY SUCCESSFUL VENDOR .....	18
7.	CHANGES IN THE WORK .....	18
8.	CHANGES IN CONTRACT PRICE .....	18
9.	TIME FOR COMPLETION .....	18
10.	CORRECTION OF WORK .....	19
11.	SUSPENSION OF WORK, TERMINATION AND DELAY .....	19
12.	PAYMENTS TO SUCCESSFUL VENDOR .....	20
13.	ACCEPTANCE OF FINAL PAYMENT AS RELEASE .....	20
14.	SEPARATE CONTRACTS .....	20
15.	SUBCONTRACTING .....	21
16.	GUARANTY .....	21
17.	SAFETY .....	21
18.	TEMPORARY SERVICES .....	21
19.	COMMUNICATION .....	21
20.	UNDOCUMENTED WORKERS .....	21
	BID BOND .....	22
	FORM OF BID .....	23
	REFERENCES .....	24
	ADDENDA ACKNOWLEDGMENT .....	25
	INDIVIDUAL PRINCIPAL .....	26
	VENDOR'S AFFIDAVIT OF QUALIFICATION TO BID .....	27
	NON-COLLUSIVE AFFIDAVIT .....	28
	NOTICE OF AWARD .....	29
	CONTRACT .....	30
	NOTICE TO PROCEED .....	32
	SECTION IV: SCOPE OF WORK .....	33
1.	GENERAL .....	33
2.	WORK INCLUDED .....	33
3.	MATERIALS PROVIDED BY THE TOWN TO BE INSTALLED UNDER THE CONTRACT .....	34
4.	WORK BY OTHERS NOT INCLUDED IN THIS CONTRACT .....	34
5.	CONTINGENT UNIT PRICES .....	34
6.	BID ALTERNATE .....	34
7.	SCHEDULE AND SEQUENCE OF WORK .....	34
8.	VENDORS HOURS AND MANNER OF WORK .....	34
9.	VENDOR QUALIFICATIONS .....	34
10.	AWARD .....	34
11.	BILLING AND PAYMENT .....	35
12.	REPAIR OF DAMAGED AREAS .....	35
13.	WARRANTY PERIOD .....	35
14.	WAGE RATES .....	35
15.	SAFETY .....	35
16.	OTHER WORK BY THE TOWN .....	35
17.	CLEAN UP .....	35
18.	COMMUNICATION .....	35
19.	TOWN CONSTRUCTION STANDARDS: .....	35
	SECTION 02060 DEMOLITION .....	36
1.	PART 1 GENERAL .....	36
2.	PART 2 PRODUCTS (INTENTIONALLY OMITTED) .....	36
3.	PART 3 EXECUTION .....	36
	SECTION 05050 HARDWARE .....	38
1.	PART 1 GENERAL .....	38
2.	PART 2 PRODUCTS .....	38
	SECTION 6100 CARPENTRY .....	39
1.	PART 1 GENERAL .....	39
2.	PART 2 PRODUCTS .....	39
3.	PART 3 EXECUTION .....	39

## SECTION I: INTRODUCTION

1. PURPOSE
  - 1.1. The purpose of this Request for Bid is for the Town of Ocean City (“Town”) to contract for Eagle’s Landing Cart Bridge Renovations (“Work”) and for said Work to be in conformity with the requirements contained herein (“Bid Document(s”).
2. CLARIFICATION OF TERMS
  - 2.1. Professional firms, organizations, or individuals that submit a bid for award of a contract (“Contract”) are referred to as vendors (“Vendors”) in this Bid Document. The Vendor that is awarded the Contract is herein referred to as the (“Successful Vendor”).
3. QUESTIONS AND INQUIRIES
  - 3.1. For information regarding Bid Documents and bidding requirements, please contact Catrice Parsons at [cparsons@oceancitymd.gov](mailto:cparsons@oceancitymd.gov) or call 410-723-6647.
  - 3.2. Copies of the Bid Documents are available on the Town’s [website](#) or by calling (410) 723-6647 during normal business hours.
4. FILLING OUT BID DOCUMENTS
  - 4.1. Use only forms supplied by the Town.
  - 4.2. Submit one (1) unbound original and one (1) bound copy.
  - 4.3. Bids Documents should be complied as follows: (1) Cover letter, (2) Form of Bid, (3) References, (4) Individual Principal Document, (5) Vendor’s Affidavit of Qualification to Bid (6) Non-Collusive Affidavit, (7) Signed addenda, if necessary (8) Bid Bond.
  - 4.4. All blanks on the Bid Documents will need to be filled in electronically or manually in ink.
  - 4.5. Where so indicated by the make-up of the Bid Documents, sums will be expressed in both words and figures, and in the case of a discrepancy between the two, the amount written in words will govern. In the event there is a discrepancy between the unit price and the extended totals, the unit prices will govern.
  - 4.6. Any interlineation, alteration, or erasure will be initialed by the signer of the Bid Documents.
  - 4.7. Each copy of the Bid Documents will be signed by the person(s) legally authorized to bind the Vendor to a contract, using the legal name of the signer. Bid Documents submitted by an agent will have a current Power of Attorney attached certifying the agent’s authority to bind the Vendor.
  - 4.8. Vendor will supply all information and submittals required by the Bid Documents to constitute a proper and responsible “Completed Bid Document” package.
  - 4.9. Any ambiguity in the Bid Documents as a result of omission, error, lack of clarity or non-compliance by the Vendor with specifications, instructions, and/or all conditions of bidding will be construed in the light most favorable to the Town.
5. SUBMISSION OF BID DOCUMENTS
  - 5.1. All copies of the Bid Documents and any other documents required to be submitted with the Bid Documents will be enclosed in a **sealed envelope**. The envelope will be addressed to the Town of Ocean City, Attn: City Manager; Room 230, 301 N. Baltimore Avenue, Ocean City, MD 21842 and will be identified with the Work name: **Eagle’s Landing Cart Bridge Renovations** and the Vendor’s name, address, and license number. If the Bid Documents are sent by mail, the sealed envelope will be enclosed in a separate mailing envelope with the notation “**SEALED BID DOCUMENTS ENCLOSED-Eagle’s Landing Cart Bridge Renovations**” on the face thereof.
    - 5.1.1. **Sealed Bid Documents are due by 4:00 p.m. on Monday, September 30, 2019 and will be opened at 1:00 p.m. Tuesday, October 01, 2019. Bids are to be submitted to Town of Ocean City, Attn: City Manager; Room 230, 301 N. Baltimore Avenue, Ocean City, MD 21842. Bids will be opened in Council Chamber at the preceding address.**

- 5.2. Bid Documents will be deposited at the designated location prior to the time and date for receipt of Bid Documents as indicated in the Advertisement or Request for Bid, or any extension made by Addendum. Bid Documents received after the time and date for receipt will be returned unopened.
- 5.3. Vendor will assume full responsibility for taking whatever measures necessary to ensure that the Bid Documents reach the Town's office prior to the local time and date specified for receipt of Bid Documents. The Town will NOT BE RESPONSIBLE for any Bid Document delayed in the postal or other delivery service nor any late Bid Document, amendment, or request for withdrawal of Bid Document, received after the Bid Document submission date.
- 5.4. Vendors, or their authorized agents, are expected to fully inform themselves as to the conditions, requirements, and specifications before submitting Bid Documents; failure to do so will be at the Vendor's own risk.
- 5.5. A fully executed Affidavit of Qualification to Bid will be attached to each Bid Document.
- 5.6. MINORITY VENDORS ARE ENCOURAGED TO PARTICIPATE.
- 5.7. All Vendor submitted Bid Documents will be valid for a minimum of sixty (60) days from the date of Bid Document opening. Vendors cannot withdraw their Bid Documents within sixty (60) days after the Bid Opening Date.
- 5.8. Email or faxed Bid Documents will not be accepted.
6. OPENING OF BID DOCUMENTS
  - 6.1. Bid Documents received on time will be opened publicly and vendor's names and total costs will be read aloud for the record.
  - 6.2. The Contract will be awarded or all Bid Documents will be rejected within sixty (60) days from the date of the Bid Document opening.
7. ACCEPTANCE OR REJECTION OF BID DOCUMENTS
  - 7.1. Unless otherwise specified, the Contract will be awarded to the lowest price and to the most RESPONSIBLE and RESPONSIVE Vendor complying with the provisions of the Bid Documents, provided the Bid price is reasonable, does not exceed the funds available, and it is in the best interest of the Town to accept it. The Town reserves the right to reject the Bid Documents of any Vendor who has previously failed to perform properly in any way or complete on time contracts of a similar nature; or a Bid Document from a Vendor who, investigation shows, is not in a position to perform the Contract; or Bid Documents from any person, firm, or corporation which is in arrears or in default to the Town for any debt or contract.
  - 7.2. Completed Bid Documents from Vendors debarred from doing business with the State of Maryland or the Federal Government will not be accepted.
  - 7.3. Conditional or qualified bids will not be accepted.
  - 7.4. In determining a Vendor's RESPONSIBILITY, the Town may consider the following qualifications, in addition to price:
    - 7.4.1. Ability, capacity, and skill to provide the commodities or services required within the specified time, including future maintenance and service, and including current financial statement or other evidence of pecuniary resources and necessary facilities.
    - 7.4.2. Character, integrity, reputation, experience and efficiency.
    - 7.4.3. A minimum of Five (5) years providing the goods/services described in this Bid Document under the Vendor name that is submitting a Completed Bid Document, with references to validate this requirement.
    - 7.4.4. Quality of past performance on previous or existing contracts, including a list of current and past contracts and other evidence of performance ability.
    - 7.4.5. Previous and existing compliance with laws and ordinances relating to contracts with the Town and to the Vendor's employment practices.
    - 7.4.6. Evidence of adequate insurance to comply with Contract terms and conditions.
    - 7.4.7. Statement of current work load and capacity to perform/provide the Goods and/or Services.

- 7.4.8. Explanation of methods to be used in fulfilling the Contract.
- 7.4.9. The Vendor, if requested, will be prepared to supply evidence of its qualifications, listed above, and its capacity to provide/perform the Goods and/or Services; such evidence to be supplied within a specified time and to the satisfaction of the Town.
- 7.5. In determining a Vendor's RESPONSIVENESS, the Town will consider whether the Bid Document conforms in all material respects to the Bid Documents. The Town reserves the right to waive any irregularities that may be in its best interest to do so.
- 7.6. The Town will have the right to reject any and all Bid Documents, where applicable to accept in whole or in part, to add or delete quantities, to waive any informalities or irregularities in the Bid Document received, to reject a Bid Document not accompanied by required Bid security or other data required by the Bid Documents, and to accept or reject any Bid Document which deviates from specifications when in the best interest of the Town. Irrespective of any of the foregoing, the Town will have the right to award the Contract in its own best interests.
8. NOTICE TO VENDORS
- 8.1. Before a Vendor submits the Bid Documents it will need to become fully informed as to the extent and character of the Work required and are expected to completely familiarize themselves with the requirements of this Bid Document's specifications including examination of site, review of drawings, and any Addenda. Failure to do so will not relieve the Vendor of the responsibility to fully perform in accordance therewith. No consideration will be granted for any alleged misunderstanding of the material to be furnished or the Work to be performed, it being understood that the submission of a Bid Document is an agreement with all of the items and conditions referred to herein.
- 8.2. The Successful Vendor will supply the names and addresses of major material suppliers and subcontractors when requested to do so by the Town.
9. PRE-BID MEETING
- 9.1. A pre-bid meeting will be held in the Club House at Eagle's Landing Golf Course on Thursday, September 12, 2019 at 10:00 a.m., located at 12367 Eagle's Nest Road, Berlin, MD 21811 for any questions concerning the Bid Documents.

**END OF SECTION**

## **SECTION II: GENERAL INFORMATION**

1. ECONOMY OF BID DOCUMENTS
  - 1.1. Bid Documents will be prepared simply and economically, providing straightforward and concise description of the Vendor's capabilities to satisfy the requirements of the Bid Documents. Emphasis should be on completeness and clarity of content. Elaborate brochures and other representations beyond that sufficient to present a complete and effective Bid Document are neither required nor desired.
2. RESPONSIBILITIES OF THE VENDOR
  - 2.1. The Vendor will be responsible for the professional quality and technical accuracy of their advice and other Work furnished in the Bid Documents. The Vendor will perform the System with the degree of skill that is normally exercised by recognized professionals as the Standard of Care with respect to Systems of a similar nature.
  - 2.2. Neither the Town's review, approval or acceptance of, nor receipt of payment for any of the work/services required under the awarded Contract will be construed to operate as a waiver of any rights under the Contract or any cause of action arising out of the performance of the Contract, and the Vendor will be liable to the Town in accordance with applicable law for all damages to the Town caused by the Vendor's negligent performance of the Contract.
  - 2.3. The rights of the Town provided for under the awarded Contract are in addition to any rights and remedies provided by law.
3. PROPRIETARY INFORMATION OR TRADE SECRETS
  - 3.1. The Vendor may invoke proprietary information or trade secret protection for submission of any data/material by (1) identifying the data/material in a written description, (2) clearly marking the data/material as proprietary, and (3) providing a written statement detailing the reasons why protection is necessary. The Town reserves the right to ask for additional clarification prior to establishing protection.
4. OWNERSHIP OF MATERIALS
  - 4.1. Ownership of all material and documentation originated and prepared pursuant to the Bid Documents will belong exclusively to the Town and is subject to public inspection in accordance with the Freedom of Information Act. Trade secrets or proprietary information submitted by a Vendor in connection with a procurement transaction will not be subject to disclosure under the Freedom of Information Act. However, the Vendor must invoke the protections of this section and be in accordance with Section 3.1.
5. CONTRACT AWARD
  - 5.1. A written award by the Town to the Successful Vendor in the form of a contract document will result in a binding Contract. If the Successful Vendor fails or refuses to sign and deliver the Contract and the required insurance documentation, the Town will have the right to award to the next highest scoring responsible and responsive Vendor. The Successful Vendor will be required to execute the Contract within fourteen (14) calendar days from the date on the Notice of Award letter. The Town will send the Contract with the Notice of Award letter.
  - 5.2. Bid Documents and Contracts issued by the Town will bind the Vendor to applicable conditions and requirements herein set forth, unless otherwise specified in the Bid Documents, and are subject to all federal, state, and municipal laws, rules, regulations, and limitations.
  - 5.3. Town personal property taxes ("Taxes") must be on a current basis; if any such Taxes are delinquent, they must be paid before award of Contract. Failure to pay will result in the award of Contract to another Vendor.
  - 5.4. The Town reserves the right to engage in individual discussions and interviews with those Vendors deemed fully qualified, responsible, suitable and professionally competent to provide the required work/services should the work/service size warrant it. Vendors will be encouraged to elaborate on their

qualifications, performance data, and staff expertise. Proprietary information from competing Vendors will not be disclosed to the public or to competitors.

6. NOTICE TO PROCEED

6.1. The Town will issue a Notice to Proceed within ten (10) calendar days from the execution of the Contract. If for any reason the Notice to Proceed cannot be issued within ten (10) days, from the execution of the Contract, the Town and the Vendor, upon mutual agreement, will extend the Contract Time.

6.2. If the Town does not issue the Notice to Proceed within the ten (10) day period or within the period mutually agreed upon the Vendor may terminate the Contract without further liability on the part of either party.

7. AUDIT

7.1. The Successful Vendor agrees to retain all books, records, and other documents relative to the awarded Contract for five (5) years after final payment, or until audited. The Town, its authorized agents, and/or State auditors will have full access to and the right to examine any of said materials during said period.

8. NONPERFORMANCE

8.1. The Town reserves the right to inspect all operations and to withhold Services for any goods not performed or not performed in accordance with the specifications in this Bid Document. Errors, omissions or mistakes in performance will be corrected at no cost to the Town. Failure to do so will be cause for Cancelling the Contract. In addition, if deficiencies are not corrected in a timely manner, the Town may characterize the Successful Vendor as uncooperative, which may jeopardize future solicitations.

9. MODIFICATION OR WITHDRAWAL OF BID DOCUMENTS

9.1. A Bid Document may not be modified, withdrawn, or cancelled by the Vendor during the stipulated time period following the time and date designated for the receipt of Bid Documents, and each Vendor so agrees in submitting Bid Documents.

10. DEFAULT

10.1. The Contract may be cancelled or annulled by the Town in whole or in part by written notice of default to the Successful Vendor upon non-performance, violation of Contract terms, delivery failure, bankruptcy or insolvency, any violation of state or local laws, or the making of an assignment for the benefit of creditors. An award may then be made to the next most highly rated Vendor, or when time is of the essence, similar commodities and/or service may be purchased on the open market. In either event, the defaulting Vendor (or its surety) will be liable to the Town for cost to the Town in excess of the defaulted Contract price.

10.2. If the Vendor defaults under any of the Contract's terms, the Town will give to the Vendor a written notice of the default ("Cure Notice"). The Vendor will have seven (7) days after receipt of the Cure Notice to cure the default. If the Vendor fails to cure the default within the time period, the Town may exercise those remedies granted under this Bid Document or applicable law.

11. COLLUSION/FINANCIAL BENEFIT

11.1. The Vendor certifies that its Completed Bid Document is made without any previous understanding, agreement, or connection with any person, firm, or corporation making a Bid Document for the same work/services; without prior knowledge of competitive prices; and is in all respects fair, without outside control, collusion, fraud, or otherwise illegal action.

11.2. Upon signing the Bid Document, Vendor certifies that no member of the governing body of the Town, or members of his/her immediate family, including spouse, parents or children, or any other officer or employee of the Town, or any member or employee of a Commission, Board, or Corporation controlled or appointed by the Mayor or Council has received or has been promised, directly or indirectly, any financial benefit, related to this Bid Document and subsequent Contract.

12. TAX EXEMPTION



- 12.1. The Town is exempt from Federal Excise Taxes, Maryland Sales and Use Taxes, and Transportation Taxes. This exemption cannot be used by Vendors doing business with the Town. Vendors are responsible for State Sales Tax of real property furnished and installed or constructed for the Town.
13. EQUAL EMPLOYMENT OPPORTUNITY AND NON-DISCRIMINATION
- 13.1. All Vendors are subject to, and must comply with, the provisions of all applicable state and federal anti-discrimination laws. The Town encourages equal employment opportunity to businesses owned and controlled by minorities and women.
- 13.2. The Successful Vendor will not discriminate against any employee or applicant for employment or any member of the public because of race, color, creed, religion, national origin, sex, sexual preference, disability, marital status, age; or otherwise commit an unfair employment practice. Vendor further agrees that this nondiscriminatory agreement will be incorporated by the Vendor in all contracts entered into with suppliers of commodities and services, contractors and subcontractors, and all labor organizations furnishing skilled, unskilled, and craft union skilled labor, or who may perform any such labor or services in connection with the Contract.
14. STATUS OF VENDOR
- 14.1. The Vendor will be responsible to the Town for acts and omissions of their employees, subcontractors, and their agents and employees, and other persons performing portions of the work/services under the Contract or other arrangement with the Vendor.
- 14.2. It is understood that the relationship of Vendor to the Town will be that of an "Independent Contractor." Nothing contained herein will be deemed or construed to (1) make the Vendor the agent, servant, or employee of the Town, or (2) create any partnership, joint venture, or other association between the Town and the Vendor.
15. APPLICABLE LAWS
- 15.1. Vendor will observe and comply with all applicable federal, state, and local laws and regulations in the performance of the Contract. The Contract will be construed and interpreted in accordance with the laws of the State of Maryland and all questions of performance hereunder will be determined in accordance with such laws.
16. SUSPENSION OR TERMINATION FOR CONVENIENCE
- 16.1. The Town will have the right, at any time by written notice, for its convenience, to suspend the Work under the Contract for such time as may be determined by the Town to be necessary or desirable up to ninety (90) days, unless a longer time is agreed upon in writing by both parties; and thereafter, to require resumption of the whole or any part of the Work without invalidating the provisions of the Contract.
- 16.2. The Town will have the right, at any time by written notice, for its convenience, to terminate the Work in whole or in part.
- 16.3. Any notice issued pursuant to Sections 16.1 and/or 16.2 will state the extent and effective date of such notice, except as otherwise directed, the Vendor will stop Work on the date of receipt of the Notice of Termination or other date specified in the notice; place no further orders or subcontracts for materials, services, or facilities, except as necessary for the completion of such portion of the Work not terminated.
- 16.4. The Vendor, within thirty (30) days of the Notice of Termination, will submit a final invoice reflecting Work actually furnished pursuant to the Contract to the satisfaction of the Town and for which no previous invoice was submitted to the Town.
- 16.5. In the event of a termination, pursuant to Section 16.2, the Town will pay the Vendor's expenses verified by final invoice as set forth in Section 16.4 for the following:
- 16.5.1. Completed and acceptable Work executed in accordance with the Contract prior to the effective date of termination, including fair and reasonable sums for overhead and profit for such Work;
- 16.5.2. Expenses sustained prior to the effective date of termination in performing Work and furnishing labor, materials, or equipment as required by the Contract in connection with uncompleted Work, plus fair and reasonable sums for overhead and profit.

16.6. The Vendor will not be paid on account of loss of anticipated profits or revenues or for Work not completed prior to the date of termination of the Contract.

17. TERMINATION FOR CAUSE

17.1. Either party may terminate the Contract in the event the other party has materially breached or defaulted in the performance of any of its obligations hereunder, and such default has continued for thirty (30) days after written notice thereof was provided to the breaching party by the non-breaching party. Any termination will become effective at the end of such thirty (30) day period unless the breaching party has cured any such breach or default prior to the expiration of such period. If a party defaults under any of the Contract's terms, the non-defaulting party will give the defaulting party a written notice of the default. The defaulting party has ten (10) business days after receipt of this notice to cure the default. If the defaulting party fails to cure the default within this time period, the non-defaulting party may exercise those remedies granted under the Contract or applicable law. Notwithstanding the above, in the case of a failure to pay any amount due hereunder the period for cure of any such default following notice thereof will be ten (10) days and, unless payment is made within such period, the termination will become effective at the end of such period.

18. ADDENDUM

- 18.1. No oral statements of any person will modify or otherwise affect or interpret the meaning of the Contract specifications, or the terms, conditions, or other portions of the Contract. All modifications and every request for any interpretation must be addressed to the Town of Ocean City's Procurement Manager and to be given consideration, must be received by noon on the last day for questions.
- 18.2. Any and all interpretations, corrections, revisions, and amendments will be issued by the Procurement Manager to all holders of Bid Documents in the form of written addenda. Vendors are cautioned that any oral statements made by any Town employee that materially change any portion of the Bid Documents will not be relied upon unless subsequently ratified by a formal written amendment to the Bid Document.
- 18.3. All addenda will be issued so as to be received at least five (5) days prior to the time set for receipt of Bid Documents, and will become part of the Contract and will be acknowledged in the Bid Document form. Failure of any Vendor to receive any such addenda will not relieve said Vendor from any obligation under the Bid Document as submitted.
- 18.4. Vendors are cautioned to refrain from including in their Bid Document any substitutions which are not confirmed by written addenda. To find out whether the Town intends to issue an amendment reflecting an oral statement made by any employee, contact the Town of Ocean City's Procurement Manager during normal business hours.
- 18.5. The Town of Ocean City's Procurement Manager reserves the right to postpone the Bid Document recognition for any major changes occurring in the 5-day interim which would otherwise necessitate an Addendum.

19. INSURANCE REQUIREMENTS

- 19.1. Unless otherwise required by Special Conditions for this Agreement, the Vendor will be required to purchase and maintain during the life of the Agreement the following types and amounts of insurance (minimum).
- 19.1.1. Commercial General Liability: \$1,000,000 (One million dollars) per occurrence \$2,000,000 (Two million dollars) aggregate for bodily injury and property damage.
- 19.1.2. Professional Liability: \$1,000,000 (One million dollars) per claim.
- 19.1.3. Commercial Automobile: \$1,000,000 (One million dollars) combined single limit per accident for bodily injury and property damage. Including hired, non-ownership coverage and owned vehicle coverage if company owns a vehicle.
- 19.1.4. As mandated by the Code of the State of Maryland and Employer's Liability the Vendor will be required to provide Worker's Compensation Insurance.

19.2. The Vendor will provide the Town with certificates of insurance evidencing the coverage required above. Such certificates will provide that the Town be given at least thirty (30) days prior written notice of cancellation of, intention to not renew, or material change in such coverage. Vendor will provide certificates of insurance before commencing Work in conjunction with this Agreement.

19.3. Failure to provide and continue in force such insurance as required above, will be deemed a material breach of the Agreement, will cause the Vendor to be in DEFAULT, and will operate as an immediate termination thereof. The Town reserves the right to require higher limits on any Agreement. A thirty (30) day notice in writing of cancellation or non-renewal will be furnished by certified mail to the Procurement Manager at the address listed in solicitation. The Vendor agrees to be responsible for, indemnify, defend and hold harmless the Town, its officers, agents and employees from the payment of all sums of money by reason of any claim against them arising out of any and all occurrences resulting in bodily or mental injury or property damage that may happen in connection with the Goods and/or Services performed under this Agreement including, but not limited to, claims under the Worker's Compensation Act.

19.3.1. ON THE COMMERCIAL GENERAL LIABILITY POLICY, THE TOWN MUST BE NAMED AS ADDITIONAL INSURED AND THE INSURANCE CERTIFICATE FURNISHED TO THE TOWN WILL INDICATE SUCH COVERAGE.

19.3.2. THE PROVIDING OF ANY INSURANCE REQUIRED HEREIN DOES NOT RELIEVE THE VENDOR OF ANY OF THE RESPONSIBILITIES OR OBLIGATIONS ASSUMED BY THE CONSULTANT IN THIS AGREEMENT, OR FOR WHICH THE VENDOR MAY BE LIABLE BY LAW OR OTHERWISE.

## 20. ASSIGNMENTS

20.1. Neither the Successful Vendor nor the Town will sell, transfer, assign, or otherwise dispose of the Contract or any portion thereof, or of its right, title, or interest therein, or its obligations thereunder, without the written consent of the other party.

## 21. INDEMNIFICATION

21.1. The Successful Vendor will indemnify and hold harmless the Town and their agents and employees from and against all claims, damages, losses and expenses including attorney's fees arising out of or resulting from the performance of the work/services provided that any such claims, damage, loss or expense is attributable to bodily injury, sickness, disease or death, or injury to or destruction of tangible property including the loss of use resulting therefrom; and caused in whole or in part by any negligent or willful act or omission of the Successful Vendor, and subcontractor or, anyone directly or indirectly employed by any of them, or anyone for whose acts any of them may be liable, the indemnification obligation will not be limited in any way by any limitation on the amount or type of damages, compensation or benefits payable by or for the Successful Vendor or any subcontractor or under workmen's compensation acts, disability benefit acts or other employee benefits acts.

## 22. SUBCONTRACTING

22.1. The Successful Vendor may utilize the services of specialty subcontractors on those parts of the work which, under normal contracting practices, are performed by specialty subcontractors.

22.2. The Successful Vendor will not award work/services to subcontractors, in excess of fifty (50%) percent of the Contract, without prior written approval of the Town.

22.3. The Successful Vendor will be fully responsible to the Town for the acts and omissions of its subcontractors, and of persons either directly or indirectly employed by them, as it is for the acts and omissions of persons directly employed by it.

22.4. The Successful Vendor will cause appropriate provisions to be inserted in all subcontractors relative to the work to bind subcontractors to the Successful Vendor by the terms of the Bid Documents insofar as applicable to the work of subcontractors and to give the Successful Vendor the same power as regards terminating any subcontractor that the Town may exercise over the Successful Vendor under any provision of the Bid Documents.

22.5. Nothing contained in the Contract will create any contractual relation between any subcontractor or and the Town.

23. CONTRACT CHANGES

23.1. NO CLAIMS may be made by anyone that the scope of the project or that the Vendor's Goods and/or Services have been changed (requiring changes to the amount of compensation to the Vendor or other adjustments to the Contract) UNLESS such changes or adjustments have been made by an approved WRITTEN AMENDMENT (Change Order) to the Contract signed by the Procurement Manager (and the Town Council, if required), prior to additional Goods and/or Services being initiated. Extra Goods and/or Services performed without prior, approved, written authority will be considered as unauthorized and at the expense of the Vendor.

23.2. NO ORAL conversations, agreements, discussions, or suggestions, which involve changes to the scope of the Contract, made by anyone including any Town employee, will be honored or valid. No written agreements or changes to the scope of the Contract made by anyone other than the Procurement Manager (with Town Council approval, if required) will be honored or valid.

23.3. If any Change Order in the Goods and/or Services results in a reduction in the Goods and/or Services, the Vendor will neither have, nor assert any claim for, nor be entitled to any additional compensation for damages or for loss of anticipated profits on Goods and/or Services that are eliminated.

24. AVAILABILITY OF FUNDING

24.1. Any resulting Agreement, Contract, or issuance of Purchase Orders is contingent upon the availability of funding and allocation of City funds. The City may cancel any Agreement, Contract, or Purchase Order immediately, by giving written notice to the Contractor, in the case of a reduction or elimination of funds or funding for any project, commodity or service.

25. FORCE MAJEURE

25.1. Neither party will be liable for delays, or defaults in the performance of this contract due to Acts of God or the public enemy, riots, strikes, fires, explosions, accidents, governmental action of any kind or any other causes of a similar character beyond its control and without its fault or negligence.

26. PROTESTS

26.1. To ensure fairness to all vendors and to promote open competition, the Town will actively follow-up and be consistent in responding to a vendor's protest concerning contract awards.

26.1.1. The vendor will submit to the Procurement Manager a written request for a protest meeting which will be received by the Procurement Department within 14 consecutive calendar days from the date of the contract award. The vendor's letter will contain specific reasons and any supporting documentation for the reasons, describing why they have a concern with the award. If the letter does not contain this information, or if the Procurement Manager determines that a meeting would serve no useful purpose, then the Procurement Manager may, within 10 consecutive calendar days from the date of receipt of the letter, respond in writing to the vendor and refuse the protest meeting request. Otherwise, the Procurement Manager must notify the protesting vendor within the 10 calendar day period that a protest meeting will be scheduled.

26.1.2. If the protest meeting is granted, the Procurement Manager will attempt to schedule the meeting within 10 consecutive calendar days after receipt of the letter, or as soon as possible thereafter. Within 10 consecutive calendar days from the date of the protest meeting, the Procurement Manager will respond to the vendor in writing with the decision.

27. FEDERAL TAX IDENTIFICATION NUMBER.

27.1. All Vendors must furnish upon request a federal tax identification number to the Town. Failure to provide this information could result in invoice payments being withheld.

28. BID RESULTS

28.1. Only bidders who receive awards will be notified of bid results; unsuccessful bidders will not be notified. Unsuccessful Vendors can visit the Town's website to see whom solicitations were awarded to.

29. CONFORMANCE TO BID REQUIREMENTS

29.1. Bids must conform to the requirements of the Invitation to Bid. Unless otherwise specified, all items solicitation must be new, unused and not remanufactured in any way. Bid prices must be for the unit

indicated on the Form of Bid. Bid prices must also reflect consideration of all terms and conditions contained in the Invitation to Bid. Failure to comply with all requirements may result in Bid rejection.

30. PRODUCT IDENTIFICATION

30.1. Vendors must clearly identify all products bid unless the products bid on are already specified in the Form of Bid. The Town reserves the right to reject any solicitation when the product information submitted with the solicitation is incomplete.

31. PAYMENT

31.1. Solicitations which require payment in less than 30 days after receipt of invoice or delivery of goods, whichever is later, may be rejected.

32. INVESTIGATION OF REFERENCES AND CONSIDERATION OF PAST PERFORMANCES

32.1. The Town reserves the right to investigate the references and the past performance of any Vendor, including but not limited to the Vendor's performance of similar services, compliance with specifications and contractual obligations, and its lawful payment of suppliers, sub-contractors, and workers and Vendor so agrees to the aforementioned by listing references. The Town may postpone the award or execution of the contract after the announcement of the apparent Successful Vendor in order to complete its investigation and may take the results of its investigation into account when conducting evaluations. The Town reserves the right to reject any Completed Bid Document or to reject all Completed Bid Documents at any time prior to the Town's execution of contract if it is determined to be in the best interest of the Town to do so.

33. BIDS ARE OFFERS

33.1. The Bid is the Vendor's offer to enter into a Contract pursuant to the terms and conditions specified in the Invitation to Bid, its Exhibits, and Addenda. The offer is binding on the Vendor for sixty (60) days. The Town's award of the Contract constitutes acceptance of the offer and binds the Vendor. The Vendor must be a complete offer and fully Responsive to the Invitation to Bid.

34. CONTINGENT BIDS

34.1. Vendor will not make its Completed Bid Document contingent upon the Town's acceptance of specifications or contract terms that conflict with or are in addition to those in the Invitation to Bid, its Exhibits, or Addenda.

35. REPRESENTATIONS AND WARRANTIES

35.1. Vendor represents and warrants that (1) Vendor has the power and authority to enter into and perform this Contract; (2) The individual signing for Vendor is authorized to execute this Contract on behalf of Vendor; (3) The Contract, when executed and delivered, will be a valid and binding obligation of Vendor, enforceable in accordance with its terms; (4) The work under the Contract will be performed in a good and workmanlike manner and in accordance with the highest professional standards; (5) Vendor will, at all times during the term of this Contract, be qualified, professionally competent, and duly licensed to perform the work; and (6) Vendor's name, as it appears in this Contract, is Vendor's legal name, as it will appear in the Vendor's W-9, and if Vendor is an entity rather than an individual that the entity named in the Contract is validly existing and in good standing. The warranties set forth in this Section are in addition to, and not in lieu of, any other warranties provided.

36. CONFLICT OF INTEREST

36.1. Vendor covenants that it presently has no interest and will not acquire any interest, direct or indirect, which would conflict in any manner with or prohibit Vendor's full performance of the Contract. Vendor also covenants that in the performance of the Contract no person having any such interest will be employed. Vendor further covenants that its performance of the Contract will not cause any employee of the Town to violate the Town's Conflict of Interest Policy.

37. WARRANTIES

37.1. Unless otherwise stated, all equipment will be new and current models and will carry full factory warranties. Vendor warrants all goods delivered to be free from defects in labor, material, and manufacture and will comply with the Scope of Work. All implied or express warranty provisions of the

Uniform Commercial Code are incorporated in the Contract. All warranties will run to the Town.

38. NO THIRD PARTY BENEFICIARIES

38.1. The Town and Vendor are the only parties to the Contract and are the only parties entitled to enforce its terms. Nothing in the Contract gives, is intended to give, or will be construed to give any benefit or right, whether directly or indirectly, to third persons unless such persons are individually identified by name and expressly described in the Contract as intended beneficiaries.

39. TIME IS OF THE ESSENCE

39.1. Vendor agrees that time is of the essence under the Contract.

40. FOREIGN VENDOR

40.1. If Vendor is not domiciled or registered to do business in the State of Maryland, Vendor will demonstrate its legal capacity to perform these services in the State of Maryland prior to entering into a Contract.

41. ATTACHMENTS

41.1. All attachments, addenda, schedules and exhibits which are referred to in the Contract are incorporated in the Contract.

42. MERGER

42.1. THIS CONTRACT CONSTITUTES THE ENTIRE AGREEMENT BETWEEN THE PARTIES. THERE ARE NO UNDERSTANDINGS, AGREEMENTS, OR REPRESENTATIONS, ORAL OR WRITTEN, NOT SPECIFIED IN THE CONTRACT REGARDING THE CONTRACT. NO AMENDMENT, CONSENT, OR WAIVER OF TERMS OF THE CONTRACT WILL BIND EITHER PARTY UNLESS IN WRITING AND SIGNED BY ALL PARTIES. ANY SUCH AMENDMENT, CONSENT, OR WAIVER WILL BE EFFECTIVE ONLY IN THE SPECIFIC INSTANCE AND FOR THE SPECIFIC PURPOSE GIVEN. VENDOR, BY THE SIGNATURE TO THIS CONTRACT OF ITS AUTHORIZED REPRESENTATIVE, ACKNOWLEDGES HAVING READ AND UNDERSTOOD THE CONTRACT AND VENDOR AGREES TO BE BOUND BY ITS TERMS AND CONDITIONS.

43. BID BOND

43.1. Bid Documents must be accompanied by a Bid Bond payable to the Town for Five (5%) percent of the total amount of the bid. After the analysis of the Bid Documents the Town will return Bid Bonds to all Vendors except the three (3) lowest responsive and responsible Vendors. After execution of the Contract, and receipt, execution, and approval of the Successful Vendor's payment and performance bond, the Bid Bonds of the two (2) remaining unsuccessful Vendors will be returned. A certified check may be used in lieu of a Bid Bond.

43.2. The Town, at its discretion, may consider a Vendor in default if the Vendor fails to execute the Contract, in which the Town will retain said Bid Bond.

44. CONTRACT SECURITY

44.1. The Successful Vendor will be required to provide the Town with a performance bond and payment bond, each in the amount of 100 percent of the Contract Price, with a corporate surety approved by the Town for the faithful performance of the Contract.

44.1.1. Attorneys-in-fact who sign Bid Bonds or Performance Bonds and Payment Bonds must file with each Bond a certified and effective dated copy of their power of attorney.

44.2. The Successful Vendor will within fourteen (14) days after the receipt of the Notice to Award furnish the Town with a Performance Bond and Payment Bond in penal sums equal to the amount of the Contract Price, conditioned upon the performance by the Successful Vendor of all undertakings, covenants, terms, conditions and agreements of the Bid Documents, and upon the prompt payment by the Successful Vendor to all persons supplying labor and materials in the prosecution of the Work provided by the Bid Document. Such Bonds will be executed by the Successful Vendor and corporate bonding company licensed to transact such business in the state in which the Work is to be performed and named on the current list of "Surety Companies Acceptable on Federal Bonds" as published in the Circular Number 570. The expense of these Bonds will be borne by the Successful Vendor. If at any time a surety on any such Bond is declared a bankrupt or loses its right to do business in the State of Maryland OR IS REMOVED FROM THE LIST OF SURETY COMPANIES ACCEPTED ON FEDERAL Bonds, Successful Vendor will within ten

(10) days after notice from the Town TO DO SO, SUBSTITUTE AN ACCEPTABLE Bond(s) in such form and sum and signed by such other surety or sureties as may be satisfactory to the Town.

**END OF SECTION**

### **SECTION III: GENERAL CONDITIONS**

1. DEFINITIONS-Wherever used in the BID DOCUMENTS, the following terms will have the meanings indicated which will be applicable to both the singular and plural thereof.
  - 1.1. Addenda - written or graphic instruments issued prior to the execution of the Contract, which modifies or interprets the BID DOCUMENTS, DRAWINGS, and SPECIFICATIONS, by additions, deletions, clarifications, or corrections.
  - 1.2. Bid Documents – Documents that include Bid Advertisement, Introduction, General Information, General Conditions, Supplemental General Conditions, Form of Bid, References, Exceptions, Individual Principal, Vendor’s Affidavit of Qualification to Bid, Non-Collusive Affidavit, Notice of Award, Notice to Proceed, Bid Bond, Contract, Change Order, Drawings, Specifications and Addenda.
  - 1.3. Bonds - Bid and other instruments of security, furnished by the Vendor and its surety in accordance with the Bid Documents.
  - 1.4. Change Order - A written order to the Vendor authorizing an addition, deletion or revision in the Work within the general scope of the Bid Documents, or authorizing an adjustment in the Contract Price or Contract Time.
  - 1.5. Completed Bid Documents- The offer or proposal of the Vendor submitted on the prescribed form(s) setting forth the prices for the Work to be performed.
  - 1.6. Contract Price - The total monies payable to the Vendor under the terms and conditions of the Bid Documents.
  - 1.7. Contract Time - The number of calendar days stated in the Bid Documents for the completion of the Work
  - 1.8. Field Order - A written order effecting a change in the Work not involving an adjustment in the Contract Price or an extension of the Contract Time issued by the Town to the Vendor during construction.
  - 1.9. Notice of Award - The written notice of the acceptance of the Completed Bid Documents from the Town to the Successful Vendor.
  - 1.10. Notice to Proceed - Written communication issued by the Town to the Vendor authorizing them to proceed with the Work and establishing the date of commencement of the Work.
  - 1.11. Owner - The Town of Ocean City, Maryland.
  - 1.12. Resident Work Representative - The authorized representative of the Town who is assigned to the Work site or any part thereof.
  - 1.13. Scope of Work - A part of the Bid Documents consisting of written descriptions of a technical nature of materials, equipment, construction systems, standards and workmanship.
  - 1.14. Subcontractor - An individual, firm or corporation having a direct contract with the Vendor or with any other Sub-contractor for the performance of a part of the Work at the site.
  - 1.15. Vendor - Any person, firm, or corporation submitting Completed Bid Documents for the Work.
  - 1.16. Work - All labor necessary to produce the construction required by the Bid Documents and all materials and equipment incorporated in the Work.
  - 1.17. Written Notice - Any notice to any party of the Contract relative to any part of the Contract in writing and considered delivered and the service thereof completed, when posted by certified or registered mail to the said party at its last given address, or delivered in person to said party or its authorized representative on the Work.
2. MATERIALS, SERVICES AND FACILITIES
  - 2.1. It is understood that, except as otherwise specifically stated in the Bid Documents, the Successful Vendor will provide and pay for all materials, labor, tools, equipment, water, light, power and transportation, supervision, temporary construction of any nature, and all other services and facilities of any nature whatsoever necessary to execute, complete, and deliver the Work within the specified time.



- 2.2. Materials and equipment will be so stored as to insure the preservation of their quality and fitness for the Work. Stored materials and equipment to be incorporated in the Work will be located to facilitate prompt inspection.
  - 2.3. Manufactured articles, materials, and equipment will be applied, installed, connected, erected, used, cleaned and conditioned as directed by the manufacturer.
  - 2.4. Materials, supplies and equipment will be in accordance with samples submitted by the Successful Vendor and approved by the Town.
  - 2.5. Materials, supplies or equipment to be incorporated into the Work will not be purchased by the Successful Vendor or the Subcontractor subject to a chattel mortgage or under a conditional sales contract or other agreement by which an interest is retained by the seller.
3. INSPECTION AND TESTING
- 3.1. All materials and equipment used in the construction of the Work will be subject to adequate inspection and testing in accordance with generally accepted standard, as required and defined in the Bid Documents.
  - 3.2. The Town will provide all inspection and testing services not required by the Bid Documents.
  - 3.3. The Successful Vendor will provide at its expense the testing and inspection services required by the Bid Documents.
  - 3.4. If the Bid Documents, laws, ordinances, rules, regulations or orders of any public authority having jurisdiction require any Work to specifically be inspected, tested, or approved by someone other than the Successful Vendor, the Successful Vendor will give the Town timely notice of readiness. The Successful Vendor will then furnish the Town the required certificates of inspection, testing or approval.
  - 3.5. Inspections, tests or approvals by the Town or others will not relieve the Successful Vendor from its obligations to perform the Work in accordance with the requirements of the Bid Documents.
  - 3.6. The Town and his/her representative will at all times have access to the Work. In addition, authorized representatives and agents of any participating Federal or State Agency will be permitted to inspect all work, materials, payrolls, records of personnel, invoices of materials, and other relevant data and records. The Successful Vendor will provide proper facilities for such access and observation, inspection or testing thereof.
  - 3.7. If any Work is covered contrary to the written instructions of the Town it must, if requested by the Town, be uncovered for his/her observation and replaced at the Successful Vendor's expense.
  - 3.8. If the Town considers it necessary or advisable that covered Work be inspected or tested by others, the Successful Vendor, at the Town's request, will uncover, expose or otherwise make available for observation, inspection or testing as the Town may require, that portion of the Work in question, furnishing all necessary labor, materials, tools and equipment. If it is found that, such Work is defective, exposure, observation, inspection, testing and reconstruction and an appropriate Change Order will be issued.
4. SURVEYS, PERMITS, REGULATIONS
- 4.1. Permits and licenses of a temporary nature necessary for the processing of the Work will be secured and paid for by the Successful Vendor unless otherwise stated in this Bid Document. Permits, licenses and easements for permanent structures or permanent changes in existing facilities will be secured and paid for by the Town, unless otherwise specified. The Successful Vendor observes that the Bid Documents are at variance therewith, it will promptly notify the Town in writing, and any necessary changes will be adjusted as provided in Section 7.CHANGES IN THE WORK.
5. PROTECTION OF WORK, PROPERTY AND PERSONS
- 5.1. Successful Vendor will be responsible for initiating, maintaining and supervising all safety precautions and programs in connection with the Work. Successful Vendor will take all necessary precautions and programs in connection with the Work. Successful Vendor will take all necessary precautions for the safety of, and will provide the necessary protection to prevent damage, injury or loss to all employees on the Work and other persons who may be affected thereby, all the Work and all materials or equipment

to be incorporated therein, whether in storage on off the site, and other property at the site or adjacent thereto, including trees, shrubs, lawns, walks, pavements, roadways, structures and utilities not designated for removal, relocation or replacement in the course of construction.

- 5.2. Successful Vendor will comply with all applicable laws, ordinances, rules, regulations and orders of any public body having jurisdiction. Successful Vendor will erect and maintain, as require by the conditions and progress of the Work, all necessary safeguards for safety and protection. Successful Vendor will notify owners of adjacent utilities when progress of the Work may affect them. The Successful Vendor will remedy all damage, injury or loss to any property caused, directly or indirectly, in whole or in part, by Successful Vendor, any Subcontractor or anyone directly or indirectly employed by any of them or anyone for whose acts any of them be liable.
  - 5.3. In emergencies affecting the safety of persons or the Work or property at the site or adjacent thereto, the Successful Vendor, without special instruction or authorization from the Town or Town, will act to prevent threatened damage, injury or loss. Successful Vendor will give the Town prompt Written Notice of any significant changes in the Work or deviations from the Bid Documents caused thereby, and a Change Order will thereupon be issued covering the changes and deviations involved.
6. SUPERVISION BY SUCCESSFUL VENDOR
- 6.1. The Successful Vendor will supervise and direct the Work. Successful Vendor will be solely responsible for the means, methods, techniques, sequences and procedures of construction. Successful Vendor will employ and maintain on the Work site a qualified supervisor or superintendent who will have been designated in writing by the Successful Vendor as the Successful Vendor's representative at the site. The supervisor will have full authority to act on behalf of the Successful Vendor and all communications given to the supervisor will be as binding as if to the Successful Vendor. The Supervisor will be present on the site at all times as required to perform adequate supervision and coordination of the Work.
7. CHANGES IN THE WORK
- 7.1. The Town may at any time, as the need arises, order changes within the scope of the Work without invalidating the Contract. If such changes increase or decrease the amount due under the Bid Document, or in the Contract Time required for performance of the Work, an equitable adjustment will be authorized by Change Order.
  - 7.2. The Town, also, may at any time, by issuing a Field Order, make changes in the details of the Work. The Successful Vendor will proceed with the performance of any changes in the Work so ordered by the Town unless the Successful Vendor believes that such Field Order entitles it to a change in Contract Price and/or Time in which event it will give the Town Written Notice thereof within seven (7) days after the receipt of the ordered change. Thereafter the Successful Vendor will not execute such changes pending the receipt of an executed Change order or further instruction from the Town.
8. CHANGES IN CONTRACT PRICE
- 8.1. The Contract Price may be changed only by a Change Order. The value of any Work covered by a Change Order or of any claim for increase or decrease in the Contract Price will be determined by one or more of the following methods in the order of precedence listed below:
    - 8.1.1. Unit prices previously approved.
    - 8.1.2. An agreed lump sum.
    - 8.1.3. The actual cost for labor, direct overhead, materials, supplies equipment, and other services necessary to complete the Work. In addition, there will be added an amount to be agreed upon but not to exceed fifteen (15%) percent of the actual cost of the Work to cover the cost of general overhead and profit.
9. TIME FOR COMPLETION
- 9.1. The date of beginning and the time for completion of the Work are essential conditions of the Bid Documents and the Work embraced will be commenced on a date specified in the Notice to Proceed.
  - 9.2. The Successful Vendor will proceed with the Work at such rate of progress to insure full completion within the Contract Time. It is expressly understood and agreed, by and between the Successful Vendor and the

Town, that the Contract Time for the completion of the Work described herein is a reasonable time, taking into consideration the average climatic and economic conditions and other factors prevailing in the locality of the Work.

10. CORRECTION OF WORK

10.1. The Successful Vendor will promptly remove from the premises all Work rejected by the Town for failure to comply with the Bid Documents, whether incorporated in the construction or not, and the Successful Vendor will promptly replace and re-execute the Work in accordance with the Bid Documents and without expense to the Town and will bear the expense of making good all Work of other Vendors destroyed or damaged by such removal or replacement.

10.2. All removal and replacement Work will be done at the Successful Vendor's expense. If the Successful Vendor does not take action to remove such rejected Work within ten (10) days after receipt of Written Notice, the Town may remove such Work and store the materials at the expense of the Successful Vendor.

11. SUSPENSION OF WORK, TERMINATION AND DELAY

11.1. The Town may suspend the Work or any portion thereof for a period not more than ninety (90) days or such further time as agreed upon by the Successful Vendor which notice will fix the date on which Work will be resumed. The Successful Vendor will be allowed an increase in the Contract Price or an extension of the Contract Time, or both, directly attributable to any suspension.

11.2. If the Successful Vendor is adjudged a bankrupt or insolvent, or if he makes a general assignment for the benefit of his creditors, or if a trustee or receiver is appointed for the Successful Vendor or for any of its property, or if it files a petition to take advantage of any debtor's act, or to reorganize under the bankruptcy or applicable laws, or if it repeatedly fails to make prompt payments to Subcontractors or for labor, materials or equipment or if it disregards laws, ordinances, rules, regulations or orders of any public body having jurisdiction of the Work or if it disregards the authority of the Town, or if it otherwise violates any provision of the Bid Documents, then the Town may, without prejudice to any other right or remedy and after giving the Successful Vendor and its surety a minimum of ten (10) days from delivery of a Written Notice, terminate the services of the Successful Vendor and finish possession of the Work and of all materials, equipment, tools, construction equipment, and all machinery thereon owned by the Successful Vendor will not be entitled to receive any further payment until the Work is finished. If the unpaid balance of the Contract Price exceeds the direct and indirect costs of completing the Work, including compensation for additional professional service, such excess will be paid to the Successful Vendor. If such costs exceed such unpaid balance, the Successful Vendor will pay the difference to the Town. Such costs incurred by the Town will be determined by the Town and incorporated in a Change Order.

11.3. Where the Successful Vendor's services have been so terminated by the Town, said termination will not affect any right of the Town against the Successful Vendor then existing or which may thereafter accrue. Any retention or payment of monies by the Town due the Successful Vendor will not release the Successful Vendor from compliance with the Bid Documents.

11.4. After ten (10) days from delivery of a Written Notice to the Successful Vendor and the Town, the Town may, without prejudice to any other right or remedy, elect to abandon the Work and terminate the Contract. In such case, the Successful Vendor will be paid for all Work executed and any expense sustained plus reasonable profit.

11.5. If, through no act or fault of the Successful Vendor, the Work is suspended for a period of more than ninety (90) days by the Town or under an order of court or other public authority, or the Town fails to act on any request for payment within thirty (30) days after it is submitted, or the Town fails to pay the Successful Vendor substantially the sum approved by the Town or awarded by arbitrators within thirty (30) days after it is submitted, or the Town fails to pay the Successful Vendor substantially the sum approved by the Town or awarded by arbitrators within thirty (30) days of its approval and presentation, then the Successful Vendor may, after ten (10) days from delivery of a Written Notice to the Town,

terminate the Contract and recover from the Town payment for all Work executed and all expenses sustained. In addition and in lieu of terminating the Contract, if the Town has failed to act on a request for payment or if the Town has failed to make any payment as aforesaid, the Successful Vendor may upon ten (10) days Written Notice to the Town and the Town stop the Work until it has been paid all amounts then due, in which event and upon resumption of the Work, Change Orders will be issued for adjusting the Contract Price or extending the Contract Time or both to compensate for the cost and delays attributable to the stoppage of the Work.

11.6. If the performance of all or any portion of the Work is suspended, delayed, or interrupted as a result of a failure of the Town or Town to act within the time specified in the Bid Documents, or if no time is specified, within a reasonable time, an extension of the Contract Time will be made by Change Order. Extension of time will be the Successful Vendor's exclusive remedy for any delay no matter how or by whom caused.

## 12. PAYMENTS TO SUCCESSFUL VENDOR

12.1. Upon completion and acceptance of the Work, the Town will issue a certificate attached to the final payment request that the Work has been accepted by him/her, under the conditions of the Bid Documents. The entire balance found to be due the Successful Vendor, except such sums as may be lawfully retained by the Town, will be paid to the Successful Vendor within thirty (30) days of completion and acceptance of the Work.

12.2. The Successful Vendor will indemnify and save the Town or the Town's agents harmless from all claims growing out of the lawful demands of Subcontractors, laborers, workmen, mechanics, material men, and furnishers of machinery and parts thereof, equipment, tools, and all supplies, incurred in the furtherance of the performance of the Work. The Successful Vendor will, at the Town's request, furnish satisfactory evidence that all obligations of the nature designated above have been paid, discharge whereupon payment to the Successful Vendor will be resumed, in accordance with the terms of the Bid Documents, but in no event will the provisions of this paragraph be construed to impose any obligations upon the Town to either the Successful Vendor, its surety, or any third party. In paying any unpaid bills of the Successful Vendor, any payment so made by the Town will be considered as a payment made under the Bid Documents by the Town to Successful Vendor and the Town will not be liable to the Successful Vendor for any such payments made in good faith.

12.3. If the Town fails to make payment thirty (30) days after approval by the Town, in addition to other remedies available to the Successful Vendor, there will be added to each such payment interest at the maximum legal rate commencing on the first day after said payment is due and continuing until the payment is received by the Successful Vendor.

## 13. ACCEPTANCE OF FINAL PAYMENT AS RELEASE

13.1. The acceptance by the Successful Vendor of final payments will be and will operate as a release to the Town of all claims and all liability to the Successful Vendor other than claims in stated amounts as may be specifically excepted by the Successful Vendor for all things done or furnished in connection with this Work relating to or arising out of this Work. Any payment, however, final or otherwise, will not release the Successful Vendor or his sureties from any obligations under the Bid Documents.

## 14. SEPARATE CONTRACTS

14.1. The Town reserves the right to let other contracts in connection with this Work. The Successful Vendor will afford other Vendors reasonable opportunity for the introduction and storage of their materials and the execution of their Work, and will properly connect and coordinate its Work of any other Successful Vendor, the Successful Vendor will inspect and promptly report to the Town any defects in such Work that render it unsuitable for such proper execution and results.

14.2. The Town may perform additional Work related to the Work by itself, or it may let other contracts containing provisions similar to these. The Successful Vendor will afford Vendors who are parties to such Contracts (or the Town, if it is performing the additional Work itself), reasonable opportunity for the

introduction and storage of materials and equipment and the execution of Work, and will properly connect and coordinate its Work with theirs.

14.3. If the performance of additional Work by other Vendors or the Town is not noted in the Bid Documents prior to the execution of the Contract, written notice thereof will be given to the Successful Vendor prior to starting any such additional Work. If the Successful Vendor believes that the performance of such additional Work by the Town or others involves it in additional expense or entitles it to an extension of the Contract Time, it may make a claim therefore as provided in Sections 14 and 15.

#### 15. SUBCONTRACTING

15.1. The Successful Vendor may utilize the services of specialty Subcontractors on those parts of the Work which, under normal contracting practices, are performed by specialty Subcontractors.

15.2. The Successful Vendor will not award Work to Subcontractors(s), in excess of fifty (50%) percent of the Contract Price, without prior written approval of the Town.

15.3. The Successful Vendor will be fully responsible to the Town for the acts and omissions of its Subcontractors, and of persons either directly or indirectly employed by them, as it is for the acts and omissions of persons directly employed by him.

15.4. The Successful Vendor will cause appropriate provisions to be inserted in all subcontracts relative to the Work to bind Subcontractors to the Successful Vendor by the terms of the Bid Documents insofar as applicable to the Work of Subcontractors and to give the Successful Vendor the same power as regards terminating any subcontract that the Town may exercise over the Successful Vendor under any provision of the Bid Documents.

15.5. Nothing contained in the Contract will create any contractual relation between any Subcontractor and the Town.

#### 16. GUARANTY

16.1. Successful Vendor will, unless otherwise indicated, guarantee all materials and equipment furnished and Work performed for a period of one (1) year from completion of Work. Successful Vendor warrants and guarantees for a period of one (1) year from the date of completion of Work that the completed system is free from all defects due to faulty materials or workmanship and the Successful Vendor will promptly make such corrections as may be necessary by reason of such defects. The Town will give notice of observed defects with reasonable promptness. In the event that the Successful Vendor should fail to make such repairs, adjustments, or other Work that may be made necessary by such defects, the Town may do so and charge the Successful Vendor the cost thereby incurred.

#### 17. SAFETY

17.1. The Vendor will observe and abide by all safety and fire regulations of the Town. It will be the full responsibility of the Vendor to maintain a safe work environment as well as ensure the safety of the public as pertaining to this Work. No part of a structure will be loaded in excess of design load. All open holes, trenches, excavations and obstacles will be barricaded during non-working hours and lighted at night, to ensure the public safety.

#### 18. TEMPORARY SERVICES

18.1. The Vendor will pay for all fuel, electric current and water required for construction purposes unless otherwise stated in this Bid Document.

#### 19. COMMUNICATION

19.1. If Vendor or Vendor's Subcontractors employ, on the job site, employees who are unable to communicate by English language, Vendor will have on the job site, available during all working hours, a supervisor or foreman who can translate for purposes of communication with Town's representatives.

#### 20. UNDOCUMENTED WORKERS

20.1. Vendor hereby certifies that its hiring practices, at all times, comply with Federal statutes, rules and regulations relative to hiring of undocumented workers.

**BID BOND**

KNOW ALL MEN BY THESE PRESENTS, that we, the undersigned, \_\_\_\_\_ as Surety, are hereby held and firmly bound unto THE TOWN OF OCEAN CITY as Town in the penal sum of \_\_\_\_\_ for the payment of which, well and truly to be made, we hereby jointly and severally bind ourselves, successors and assigns.

Signed, this \_\_\_\_\_ day of \_\_\_\_\_, 2019.

The condition of the above obligation is such that whereas the Principal has submitted to \_\_\_\_\_ certain BID DOCUMENTS, attached hereto and hereby made a part hereof to enter into a contract in writing, for Canal Dredging.

NOW, THEREFORE,

(a) If said BID DOCUMENTS will be accepted and the Principal will execute and deliver a contract in the form of Contract attached hereto (properly completed in accordance with said BID DOCUMENTS) and will furnish a BOND for its faithful performance of said Contract, and for the payment of all persons performing labor or furnishing materials in connection therewith, and will in all other respects perform the Contract created by the acceptance of said BID DOCUMENTS, then this obligation will be void, otherwise the same will remain in force and effect; it being expressly understood and agreed that the liability for the Surety for any and all claims hereunder will, in no event, exceed the penal amount of this obligation as herein stated.

The Surety, for value received, hereby stipulates and agrees that the obligations of said Surety and its BOND will be in no way impaired or affected by any extension of the time within which the TOWN may accept such BID DOCUMENTS; and said Surety does hereby waive notice of any such extension.

IN WITNESS WHEREOF, the Principal and the Surety have hereunto set their hands and seals, and such of them as are corporations have caused their corporate seals to be hereto affixed and these presents to be signed by their proper officers, the day and year first set forth above.

\_\_\_\_\_  
Principal

\_\_\_\_\_  
Surety

\_\_\_\_\_  
By

IMPORTANT - Surety companies executing BONDS must appear on the Treasury Department's most current list (Circular 570 as amended) and be authorized to transact business in the State of Maryland.

## FORM OF BID

To whom it may concern:

We, \_\_\_\_\_, organized and existing under the laws of the State of \_\_\_\_\_ doing business as a/an **sole proprietorship/partnership/corporation**, hereby submit our Completed Bid Documents for the Eagle's Landing Cart Bridge Renovations, as indicated in the Bid Documents.

Having carefully examined and being in compliance with the Town's Bid Documents and having received clarification on all items of conflict or upon which any doubt arose, the undersigned hereby requests consideration of our Completed Bid Documents and propose to perform all Work for EAGLE'S LANDING CART BRIDGE RENOVATIONS in strict accordance with the Contract Documents, within the time set forth therein, and at the prices stated below.

Vendor hereby agrees to commence Work under the Contract no earlier than January 06, 2020 and to fully complete the Work within sixty (60) calendar days.

Item	Description	UOM	Qty	Each \$	Extended Cost
1	Renovation of bridges # CH, 4, 7, 8, 9, 16, 17, 18a	LS	N/A	N/A	\$
2	Contingent wale replacement	PR	25	\$	\$
<b>Total Lump Sum Base Bid</b>					\$

Item	Description	UOM	Extended Cost
ALT 1	Renovation of bridges #10, 11, and 18b	LS	\$
<b>Total Lump Sum Bid for ALT 1</b>			\$

**NOTE: THIS BID FORM MUST BE SIGNED BY AN OFFICER OF YOUR COMPANY OR AN AUTHORIZED AGENT FOR THIS BID TO BE CONSIDERED VALID.**

**NOTE: Completed Bid Documents will include all applicable fees.**

Is your company currently involved in any active litigation? (Yes)\_\_\_\_ (No)\_\_\_\_ CHECK One.

Is your company currently involved in any mergers or acquisitions? (Yes)\_\_\_\_ (No)\_\_\_\_ CHECK One.

\*If you answered Yes to either of the two questions directly above, please attach documentation to your Bid describing further.

Respectfully submitted,

\_\_\_\_\_  
Signature

\_\_\_\_\_  
License Number

\_\_\_\_\_  
Date

\_\_\_\_\_  
Address

\_\_\_\_\_  
Title

(Affix Corporate Seal)

## REFERENCES

List three (3) references for similar Work successfully completed in the last 5 years. Include contact name, address, telephone number and goods sold.

Company Name:		Company Name:	
Type of Work:		Type of Work:	
Address:		Address:	
Town, State, Zip Code:		Town, State, Zip Code:	
Contact Person:		Contact Person:	
Telephone Number:		Telephone Number:	
Email Address:		Email Address:	
Date of Service:		Date of Service:	
Company Name:			
Type of Work:			
Address:			
Town, State, Zip Code:			
Contact Person:			
Telephone Number:			
Email Address:			
Date of Service:			

\_\_\_\_\_  
Sign for Identification

\_\_\_\_\_  
Printed Name



## ADDENDA ACKNOWLEDGMENT

THE VENDOR HEREBY ACKNOWLEDGES RECEIPT OF THE FOLLOWING ADDENDA.

<u>Number</u>	<u>Date</u>	<u>Initials</u>
_____	_____	_____
_____	_____	_____
_____	_____	_____

\_\_\_\_\_  
Sign for Identification

\_\_\_\_\_  
Printed Name

**INDIVIDUAL PRINCIPAL**

Vendor Name: \_\_\_\_\_

Signed By: \_\_\_\_\_ In the presence of: \_\_\_\_\_

Address of Vendor: \_\_\_\_\_ Town, State, Zip

\_\_\_\_\_

Telephone No.: \_\_\_\_\_ Fax: \_\_\_\_\_

\*\*\*\*\*

CO-PARTNERSHIP PRINCIPAL

Name of Co-Partnership: \_\_\_\_\_

Address: \_\_\_\_\_ Town, State, Zip \_\_\_\_\_

Telephone No.: \_\_\_\_\_ Fax: \_\_\_\_\_

Signed By: \_\_\_\_\_ In the presence of: \_\_\_\_\_

Partner

Witness

Signed By: \_\_\_\_\_ In the presence of: \_\_\_\_\_

Partner

Witness

Signed By: \_\_\_\_\_ In the presence of: \_\_\_\_\_

Partner

Witness

\*\*\*\*\*

CORPORATE PRINCIPAL

Name of Corporation: \_\_\_\_\_

Address: \_\_\_\_\_ Town, State, Zip

\_\_\_\_\_

Telephone No.: \_\_\_\_\_ Fax: \_\_\_\_\_

Signed By: \_\_\_\_\_ In the presence of: \_\_\_\_\_

President

Witness

Attest: \_\_\_\_\_

Corporate Secretary

.....

Affix Corporate Seal

## VENDOR'S AFFIDAVIT OF QUALIFICATION TO BID

I HEREBY AFFIRM THAT:

I, \_\_\_\_\_ am the \_\_\_\_\_  
(Printed Name) (title)  
and the duly authorized representative of the Vendor of  
\_\_\_\_\_ whose address is  
(name of corporation)

---

and that I possess the legal authority to make this affidavit on behalf of myself and the Vendor for which I am acting.

Except as described in paragraph 3 below, neither I nor the above Vendor, nor to the best of my knowledge and of its officers, directors or partners, or any of its employees directly involved in obtaining contracts with the State or any county, bi-county or multi-county agency, or subdivision of the State have been convicted of, or have pleaded nolo-contendere to a charge of, or have during the course of an official investigation or other proceeding admitted in writing or under oath acts or omissions which constitute bribery, attempted bribery, or conspiracy to bribe under the provisions of Article 27 of the Annotated Code of Maryland or under the laws of any state or federal government (conduct prior to July 1, 1977 is not required to be reported).

(State "none" or, as appropriate, list any conviction, plea or admission described in paragraph 2 above, with the date, court, official or administrative body, the individuals involved and their position with the Vendor, and the sentence or disposition, if any.)

---

---

I acknowledge that this affidavit is to be furnished to the Town, I acknowledge that, if the representations set forth in this affidavit are not true and correct, the Town may terminate any Contract awarded and take any other appropriate action. I further acknowledge that I am executing this affidavit in compliance with section 16D of Article 78A of the Annotated Code of Maryland, which provides that certain persons who have been convicted of or have admitted to bribery, attempted bribery or conspiracy to bribe may be disqualified, either by operation of law or after a hearing, from entering into contracts with the State or any of its agencies or subdivisions.

I do solemnly declare and affirm under the penalties of perjury that the contents of this affidavit are true and correct.

\_\_\_\_\_  
Sign for Identification

\_\_\_\_\_  
Printed Name

**NON-COLLUSIVE AFFIDAVIT**

\_\_\_\_\_ being first duly sworn,  
deposes and says that:

1. He/she is the \_\_\_\_\_, (Owner, Partner, Officer, Representative or Agent) of \_\_\_\_\_, the Vendor that has submitted the attached Bid Documents;
2. He/she is fully informed respecting the preparation and contents of the attached Bid Document and of all pertinent circumstances respecting such Bid Documents;
3. Such Bid Document is genuine and is not a collusive or sham Bid Document;
4. Neither the said Vendor nor any of its officers, partners, owners, agents, representatives, employees or parties in interest, including this affiant, have in any way colluded, conspired, connived or agreed, directly or indirectly, with any other Vendor, firm, or person to submit a collusive or sham Bid Document in connection with the Work for which the attached Bid Document has been submitted; or to refrain from bidding in connection with such Work; or have in any manner, directly or indirectly, sought by agreement or collusion, or communication, or conference with any Vendor, firm, or person to fix the price or prices in the attached Bid Document or of any other Vendor, or to fix any overhead, profit, or cost elements on the Bid Document price or the Bid Document price of any other Vendor, or to secure through any collusion, conspiracy, connivance, or unlawful agreement any disadvantage against (Recipient), or any person interested in the Work;
5. The price or prices quoted in the attached Bid Document are fair and proper and are not tainted by any collusion, conspiracy, connivance, or unlawful agreement on the part of the Vendor or any other of its agents, representatives, owners, employees or parties in interest, including this affiant.

Signed, sealed and delivered in the presence of:

\_\_\_\_\_  
Witness

By: \_\_\_\_\_  
Signature

\_\_\_\_\_  
Witness

\_\_\_\_\_  
Printed Name

\_\_\_\_\_  
Title

## NOTICE OF AWARD

[Vendor Name]  
[C/o \_\_\_\_\_ ]  
[Vendor Address]  
[Vendor Address]

Project Description: EAGLE'S LANDING CART BRIDGE RENOVATIONS

The Town has considered the Completed Bid Document submitted by your organization for the above referenced project. You are hereby notified that your Completed Bid Document has been accepted for EAGLE'S LANDING CART BRIDGE RENOVATIONS in the amount of: \_\_\_\_\_ (\$\_\_\_\_\_).

You are required by the Bid Documents Section II. General Information, Subsection 5.1 to execute the Contract, furnish your organizations Ocean City Business License, and furnish the Vendor's Certificate of Insurance within fourteen (14) days from the date of this Notice to you.

You are also required to return an acknowledged copy of this Notice of Award to the Town.

Date: \_\_\_\_\_  
Town of Ocean City, Maryland

By: \_\_\_\_\_

Catrice L. Parsons, Procurement Manager

### ACCEPTANCE OF NOTICE

Receipt of the Notice of Award us hereby acknowledged by:

\_\_\_\_\_ this \_\_\_\_\_ day of \_\_\_\_\_, 2019.

By: \_\_\_\_\_

Title: \_\_\_\_\_

## CONTRACT

THIS CONTRACT, made this \_\_\_\_\_ day of \_\_\_\_\_, 2019, by and between The Town of Ocean City, hereinafter called 'Town' and \_\_\_\_\_ doing business as (an individual), (a partnership), or (a corporation) hereinafter called 'Successful Vendor'.

WITNESSED: That for and in consideration for payment and agreements hereinafter mentioned:

1. Successful Vendor will commence and complete Eagle's Landing Cart Bridge Renovations.
2. Successful Vendor will furnish all of the material, supplies, tools, equipment, labor and other services necessary for the construction of the Work described herein.
3. Successful Vendor will commence the Work required by the Contract Documents no earlier than January 06, 2020 and will complete the same within sixty (60) calendar days unless the period for completion is extended otherwise by the Contract Documents.
4. Successful Vendor agrees to perform all of the Work described in the Bid Documents and comply with the terms therein for the sum of \$\_\_\_\_\_ (\_\_\_\_\_) or as shown in the Form of Bid.
5. The term 'Contract Documents' means and includes the following:
  - Advertisement
  - Section I - Introduction
  - Section II - General Information
  - Section III - General Conditions
  - Bid Bond
  - Form of Bid
  - References
  - Addenda Acknowledgement
  - Individual Principal
  - Vendor's Affidavit of Qualification to Bid
  - Non-Collusive Affidavit
  - Notice of Award
  - Contract
  - Notice to Proceed
  - Section IV - Scope of Work
  - Drawings
  - ADDENDA \_\_, dated \_\_\_\_\_.
  - Payment and Performance Bonds
  - Field Order
  - Change Order
6. The Town will pay the Successful Vendor in the manner and at such times as set forth in the Bid Documents.
7. This Contract will be binding upon all parties hereto and their respective heirs, executors, administrators, successors, and assigns.

IN WITNESS WHEREOF, the parties hereto have executed, or caused to be executed by their duly authorized officials, this Contract in duplicate each of which will be deemed an original on the date first above written.

VENDOR:

\_\_\_\_\_  
BY \_\_\_\_\_

NAME \_\_\_\_\_

TITLE \_\_\_\_\_

TOWN:

\_\_\_\_\_  
BY \_\_\_\_\_

Douglas R. Miller  
CITY MANAGER

(SEAL)

ATTEST \_\_\_\_\_

NAME \_\_\_\_\_

(SEAL)

ATTEST \_\_\_\_\_

NAME \_\_\_\_\_

**NOTICE TO PROCEED**

To:

Date:

Work: EAGLE'S LANDING CART BRIDGE RENOVATIONS

You are hereby notified to commence WORK in accordance with the Contract dated \_\_\_\_\_ on or before \_\_\_\_\_, you are to complete the WORK within sixty (60) calendar days from the Notice to Proceed. The date of completion of all WORK is therefore \_\_\_\_\_, 2019.

TOWN OF OCEAN CITY  
BY \_\_\_\_\_  
Terry McGean  
City Engineer

**NOTICE TO PROCEED**

Receipt of the above NOTICE TO PROCEED is hereby acknowledged by

\_\_\_\_\_

this \_\_\_\_\_ day of \_\_\_\_\_, 2019.

By \_\_\_\_\_

Title \_\_\_\_\_



## SECTION IV: SCOPE OF WORK

1. GENERAL
  - 1.1. The scope of work for Eagles landing Cart Bridge Renovations includes all demolition, carpentry, and associated work as indicated in the bid documents. The following items are not intended to be an all-inclusive listing of work required but will merely highlight and/or clarify specific items of this scope.
2. WORK INCLUDED
  - 2.1. The following specification sections define the work of this package:
    - 2.1.1. 02060 – Demolition
    - 2.1.2. 05050 - Hardware
    - 2.1.3. 06100 – Carpentry
  - 2.2. Provide all labor, materials (excluding wood), tools, and equipment to perform all work necessary for the renovation of the cart bridges number CH, 4, 7, 8, 9, 16, 17 & 18A
  - 2.3. Renovation of cart bridges number 10, 11, and 18b to be bid as Add Alternate #1.
  - 2.4. Remove and dispose of existing 4x6 wood curb and base.
  - 2.5. Remove and dispose of existing rope railing system at bridges #16 and #17
  - 2.6. Remove and dispose of all 2x8 wood deck boards.
  - 2.7. Remove and dispose of all 2x10 wood stringers, existing 3x10 wood stringers are to remain in place.
  - 2.8. Remove and replace any damaged 3x8 wales as directed by the Engineer. Lumber supplied by the Town of Ocean City, all hardware supplied by the Successful Vendor.
  - 2.9. Sister new 2x10 wood stringers at each 3x10 stringer. Lumber supplied by the Town, all hardware supplied by the Successful Vendor.
  - 2.10. Install new treated wood stringers to replace existing. Lumber supplied by the Town, all hardware supplied by the Successful Vendor.
  - 2.11. Install new treated wood bridge deck, lumber supplied by the Town, fasteners supplied by the Successful Vendor.
  - 2.12. Install new 4x6 curb and curb base. Install lumber supplied by the Town, all hardware supplied by the Successful Vendor.
  - 2.13. Perform daily site cleanup including demolition debris, and other debris generated as part of the Contract.
  - 2.14. Repair any damage to existing golf course caused by Successful Vendor including, but not limited to cart paths, turf, irrigation system, structures and landscaping to the satisfaction of the Course Superintendent at the Successful Vendor's expense
  - 2.15. Work with the Town's forces in the coordination and sequencing of the Work as part of the Contract to ensure that installation proceeds as efficiently as possible within the guidelines of the project schedule. Attend all progress meetings.
  - 2.16. Provide all means of transport for all materials including removal of all materials to be disposed and transporting new wood from the staging location to each site.
  - 2.17. Successful Vendor acknowledges that site space and access will be limited during the work. Successful Vendor will familiarize itself with the site access requirements and submit a list of equipment proposed for use on cart paths and bridges to the course superintendent for approval.
    - 2.17.1. All access restricted to existing cart paths and bridges with the following weight and size limits:
      - Cart paths: 10' wide or more 10,000 pounds (3/4 ton pickup)
      - Cart paths: less than 10' wide: Full size trucks prohibited. Golf course utility vehicles, bobcat style loaders, mini excavators, or other small equipment allowed.
      - Cart bridges: 3,500 pounds (golf course utility vehicle)
  - 2.18. Provide all electrical extension cords as necessary. Where available electric will be provided to the

Successful Vendor at no cost. Where not available, Successful Vendor will provide portable generators as necessary.

3. MATERIALS PROVIDED BY THE TOWN TO BE INSTALLED UNDER THE CONTRACT
  - 3.1. 2x10x18' stringers
  - 3.2. 4x6x16' curb and base
  - 3.3. 2x8 deck boards
  - 3.4. 3x8x8' wales
4. WORK BY OTHERS NOT INCLUDED IN THIS CONTRACT
  - 4.1. Any utility relocations will be completed by the Town prior to work.
5. CONTINGENT UNIT PRICES
  - 5.1. Contingent items for which the quantities are identified on the Bid Form are established for the purpose of obtaining bids on one or more pay items that may be incorporated into the project. The City Engineer will have sole discretion in determining whether and to what extent such items will be incorporated into the project. The items are not located on the plans. The estimated quantities set out on the Bid Form for such items are presented solely for the purpose of obtaining a representative bid price. The actual quantities employed may be only a fraction of, or many times the estimated quantity. Neither party will make any claims for additional compensation because of an increase, decrease, or elimination of such items.
  - 5.2. Contingent Wale replacement: Cost per each pair complete in place including hardware but excluding lumber to remove and replace damaged 3x8 wales as directed by the City Engineer.
6. BID ALTERNATE
  - 6.1. Provide all labor, materials (excluding wood), tools and equipment to remove and replace all wood decking, curb, curb base, stringers, and any damaged wales at cart bridges number 10, 11, and 18b.
7. SCHEDULE AND SEQUENCE OF WORK
  - 7.1. Schedule of Work:
    - 7.1.1. Notice to Proceed will be given on or about November 1, 2019 to allow adequate time for submittals and material delivery. No work at the site will be permitted until January 6, 2020. From January 6, 2020 the Successful Vendor will complete the work within 60 (sixty) calendar days. The Successful Vendor is responsible for coordinating its Work with the project schedule and the City Engineer to complete his Work within the allotted time.
    - 7.1.2. A maximum of 1 bridge may be closed for use at any given time.
    - 7.1.3. Coordinate bridge closures with the Golf Course Superintendent.
8. VENDORS HOURS AND MANNER OF WORK
  - 8.1. All Work performed must be coordinated with the Town's designated representative(s).
  - 8.2. Work hours will be between the hours of 7:00AM to 5:00PM, Monday through Friday, except for Town recognized Holidays.
  - 8.3. Vendor may block access to the facility on a temporary basis. Coordinate all access restrictions with the City Engineer and provide a minimum of 48 hours prior notification.
9. VENDOR QUALIFICATIONS
  - 9.1. The Successful Vendor must be licensed to perform Work in the state of Maryland as well as the Town.
  - 9.2. The Successful Vendor must provide a copy of their insurance policy covering the requested Work as described in these Bid Documents.
  - 9.3. Vendors must submit references for a minimum of three similar projects involving similar work within the past 5 years.
10. AWARD
  - 10.1. The Town reserves the right to award in part if it is deemed in the Town's best interest to do so.
  - 10.2. The Town intends to award to the lowest priced and most Responsive and Responsible Vendor(s) meeting the specifications.

11. BILLING AND PAYMENT
  - 11.1. Invoices are to be submitted to, [APFINANCE@OCEANCITYMD.GOV](mailto:APFINANCE@OCEANCITYMD.GOV), with the site name and address for which the Work was performed.
  - 11.2. Invoices must not contain any charges or fees (e.g. mileage, fuel, truck, trip, environmental, union expenses, etc.) other than labor and materials.
  - 11.3. The Town will only pay the Successful Vendor for time spent on-site performing services.
  - 11.4. Payment will be made only after performance of Work and upon receipt of proper invoice from Successful Vendor and acceptance by the Town.
12. REPAIR OF DAMAGED AREAS
  - 12.1. All disturbed or damaged areas will be restored in kind to an equal or better condition within the bid price at no additional cost to the Town.
13. WARRANTY PERIOD
  - 13.1. Warranty period for all materials and workmanship associated with this project will be one (1) year from the date of Work Completion.
14. WAGE RATES
  - 14.1. No federal wage rates other than minimum wage rates will be imposed.
15. SAFETY
  - 15.1. The Successful Vendor will observe and abide by all safety and fire regulations of the Town. It will be the full responsibility of the Successful Vendor to maintain a safe work environment as well as ensure the safety of the public as pertaining to this Work. No part of a structure will be loaded in excess of design load. All open holes, trenches, excavations, and obstacles will be barricaded during non-working hours and lighted at night, to ensure the public safety.
16. OTHER WORK BY THE TOWN
  - 16.1. The Town may, at any time, employ others in maintaining or altering existing facilities and equipment in any other work at the job site. The respective rights of the various interests involved will be established by the Town's Representative.
17. CLEAN UP
  - 17.1. The Successful Vendor will keep the work site and adjoining premises, driveways, walks, and streets clean of rubbish. The Successful Vendor will dispose of all rubbish, waste, and excess material in a manner satisfactory to the Town's Representative. Upon completion of the Work, the Successful Vendor will clean up the site and leave all construction broom clean, and all fixtures and equipment clean, washed and in usable condition.
18. COMMUNICATION
  - 18.1. If Successful Vendor or subcontractors employ, on the job site, employees who are unable to communicate by the English language, Successful Vendor will have on the job site, available during all working hours, a supervisor or foreman who can translate for purposes of communication with Town's representatives.
19. TOWN CONSTRUCTION STANDARDS:
  - 19.1. Unless noted otherwise, all Work performed will be in accordance with the latest version of the Town's Construction Standards. The Successful Vendor is required to have a copy of the Town's Construction Standards, along with the approved Plans and Specifications on the project site at all times.

**END OF SECTION**

## SECTION 02060 DEMOLITION

1. PART 1 GENERAL
  - 1.1. DESCRIPTION: Select demolition of portions of existing timber golf cart bridges at Eagles Landing Golf Course
    - 1.1.1. Remove timber curbs, bases, railings, timber deck, 2x10 stringers, and all hardware. Removed material is the property of the Successful Vendor and will be disposed of in accordance with all local, State, and Federal Laws.
    - 1.1.2. Remove damaged 3x8 wales as directed by the City Engineer.
  - 1.2. SUBMITTALS
    - 1.2.1. Submit debris disposal procedure along with certifications that all material has been disposed in accordance with State and Federal regulations.
  - 1.3. PROJECT CONDITIONS
    - 1.3.1. Protection:
      - Perform demolition work to prevent injury or damage to adjacent site including course turf and protected wetlands.
      - Protect existing structural components to remain in place.
      - Each bridge will be closed to the public during demolition and renovation. A maximum of 1 bridge may be closed at any given time.
      - Promptly repair damage to adjacent structures caused by demolition operations. Cost of repairs at the Successful Vendor's expense.
      - MATERIAL REMOVAL:
        - Dumpsters may be placed at the staging area indicated on the contract drawings.
          - ◇ Dumpsters will not be placed outside of the designated staging area.
        - Demolished materials will be promptly removed from each bridge location and transported to the designated staging area.
2. PART 2 PRODUCTS (INTENTIONALLY OMITTED)
3. PART 3 EXECUTION
  - 3.1. INSPECTION
    - 3.1.1. Examine the site, verify the extent of all demolition work required.
    - 3.1.2. Notify the City Engineer of any existing damaged structural components scheduled to remain in place including 3x10 stringers, 3x8 wales, and piling.
  - 3.2. DEMOLITION
    - 3.2.1. Perform demolition by methods of Successful Vendors choice in accordance with governing regulations.
  - 3.3. DISPOSAL OF DEMOLISHED MATERIALS
    - 3.3.1. Haul all demolished materials from each bridge location on a daily basis and transport to the designated staging area. Stockpile at staging area in either neat bundles or dumpsters, haul from site, and legally dispose of demolished material. All demolished material to be hauled from site within 14 calendar days of demolition.
    - 3.3.2. On-site burning of demolished materials is not permitted.
  - 3.4. SALVAGED MATERIALS
    - 3.4.1. Remove, store as directed by the City Engineer, and re-install all items as noted on the drawings and specifications.
    - 3.4.2. Materials not scheduled for reinstallation are property of the contractor. Remove demolished material from the site as work progresses. Storage and sale of Successful Vendor's salvaged items on the site is not permitted.
      - Off-site sale of demolished material is allowed and all proceeds from the sale of demolished

materials are the property of the Successful Vendor.

3.5. CLEANING

3.5.1. Upon completion of demolition work, clean areas within the Contract limits and remove all tools and equipment. Provide site clear, clean, free of demolished materials, and suitable for construction activity. Remove all debris.

## SECTION 05050 HARDWARE

### 1. PART 1 GENERAL

#### 1.1. Submittals:

- 1.1.1. Submit manufacturer's certifications including galvanizing for all hardware and fasteners.
- 1.1.2. Provide a samples of each fastener and hardware for approval by the City Engineer.

### 2. PART 2 PRODUCTS

- 2.1. Connector Bolts will be hex head, hot dipped galvanized ASTM A153 with one nut and two USS washers per bolt. ASTM A 307, grade A, cut threads.
- 2.2. Bolts (10" and longer) will be hex head, hot dipped galvanized ASTM A153 with one nut and two USS washers per bolt. ASTM A 307, grade A, cut threads. Minimum 6" thread length.
- 2.3. Nails
  - 2.3.1. Deck board to stringer:
    - Hand Driven: 20d, common ring shank, minimum shaft diameter of .177 inches (#7) hot dipped galvanized ASTM A153. Manufactured by MazeNails, Peru III model T-4492A or
    - Collated nail gun: 5x162 Ring Shank Hot Dipped Galvanized, minimum 5" length using minimum 0.163" heavy duty hot dipped galvanized 90,000 psi benmding, 115,000 psi tensile wire, 0.325" minimum head diameter with adhesive coating. ASTM F1667, ICC ES-1539. Manufactured by Falcon Fasteners, Scarborough, Ontario Model PSW64718 or
    - Deck Screws: will be #10-9 x 3-1/2" long, 2/3 LO root thread, coasted and galvanized steel or stainless steel, square drive heads with countersink nibbs, self drilling type 17 point.

## SECTION 6100 CARPENTRY

1. PART 1 GENERAL
  - 1.1. Description
    - 1.1.1. Install all hardware, wood stringers, wood curbs, and deck for renovation of existing golf cart bridges.
    - 1.1.2. Replace damaged wales at golf cart bridges as directed by the City Engineer
    - 1.1.3. All lumber material will be supplied by the Town.
  - 1.2. Quality Assurance
    - 1.2.1. Contractor qualifications: A minimum of 5 years' experience in heavy framing or marine contracting.
  - 1.3. Submittals
    - 1.3.1. Proposed written schedule and sequence of construction.
  - 1.4. Project Conditions
    - 1.4.1. Construction Staging and site access
      - Perform all Work to assure minimum interference with adjacent golf holes, fairways, greens and other facilities
    - 1.4.2. Provide necessary barricades and enclosures for public and worker safety.
    - 1.4.3. A maximum 1 bridge may be closed to the general public during any given time for the prosecution of this Work.
2. PART 2 PRODUCTS
  - 2.1. Material Storage and Handling:
    - 2.1.1. Town supplied lumber materials: All lumber material will be supplied by the Town and delivered to the designated staging area.
      - Successful Vendor is responsible for transporting lumber from the delivery locations at staging areas to the work area.
      - Successful Vendor is responsible for any damage or loss of wood after delivery to the staging areas.
      - All excess lumber remains the property of the Town.
      - Successful Vendor will utilize lumber in an efficient manner to minimize waste. If additional lumber material is required to complete the project and in the City Engineer's judgment the Successful Vendor has wasted or damaged the material provided, the Successful Vendor will be responsible for the additional material costs.
    - 2.1.2. Timber will be open stacked in piles at least 6 inches above the ground surface in a manner to shed water and prevent warping. Timber will be handled with rope or nylon slings to prevent the breaking of outer fibers, bruising, or penetrating the surface.
  - 2.2. Hardware and fasteners will be provided by the Successful Vendor and are specified in Section 05050.
3. PART 3 EXECUTION
  - 3.1. Preparation: Verify all dimensions and details before proceeding with carpentry Work.
  - 3.2. Installation:
    - 3.2.1. Diameter of Holes: Holes bored in timber structures will conform to the following:
      - Machine Bolts: Same as the diameter of the bolt
      - Rods: 1/16 in. larger than the diameter of the rod
      - Lag Screws: Equal to the diameter of the screw at the base of the thread.
      - Connector bolts: 1/16 in larger than the diameter of the bolt.
    - 3.2.2. Bolt Assemblies. Hex bolt heads or nuts, which come in contact with the timber or foundation bracket will be fitted with a washer of the size and type specified.

- 3.3. Countersinking: Countersinking will be done at all curb attachments.
- 3.4. Connectors: Connector holes will be bored through members to be connected. The bolt holes will be kept perpendicular to the face of the timber.
- 3.5. Framing: All timber will be accurately cut and framed to provide even bearing over the entire contact surface.
- 3.6. Stringers: Stringers will be placed in position so that knots near edges will be in the top portion of the stringer. Ends of outside stringers will be overlapped and through bolted to piling as shown on the drawings. Each stringer will be toe nailed to each wale. Do not splice stringers between wales
- 3.7. Stringers to be sistered to existing 3x10 will be nailed with 10d galvanized nails at 32" o.c. staggered top and bottom
- 3.8. Decking: Planks will be attached to every stringer using not less than two fasteners. Planks will be laid sap side up to prevent cupping.



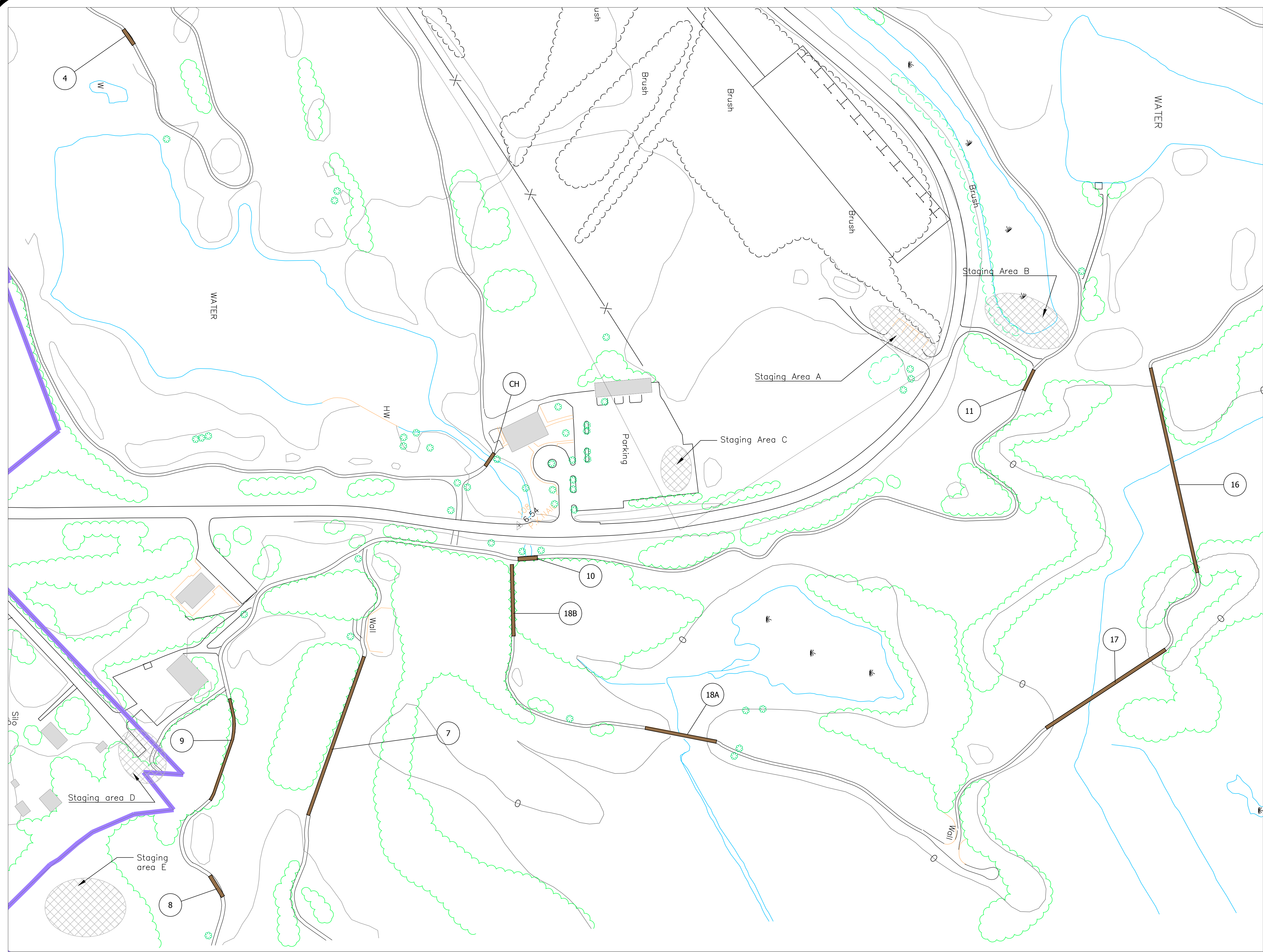

General Notes

- General Notes:  
 1) All lumber supplied by owner  
 2) All hardware hot dipped galvanized or stainless steel  
 3) Bridge access by cart path only. Coordinate all access with Course Superintendent (410)520-5264

Bridge Schedule

Mark	Length (ft)	Width (ft)
CH	37	16
4	40	8
7	373	8
8	54	8
9	230	8
10	52	8
11	52	8
16	464	8
17	321	8
18a	161	8
18b	161	8

No.	Revision/Issue	Date

Firm Name and Address  
**TOWN OF OCEAN CITY**  
 ENGINEERING DEPT,  
 301 BALTIMORE AVE.  
 OCEAN CITY, MD 21842  
 (410)289-8845

Project Name and Address  
**OCEAN CITY**  
 EAGLES LANDING  
 GOLF COURSE PROPERTY  
 CART BRIDGE LOCATIONS

GOLF TOPO  
 JULY 25, 2019  
 1"=100'

Sheet  
1

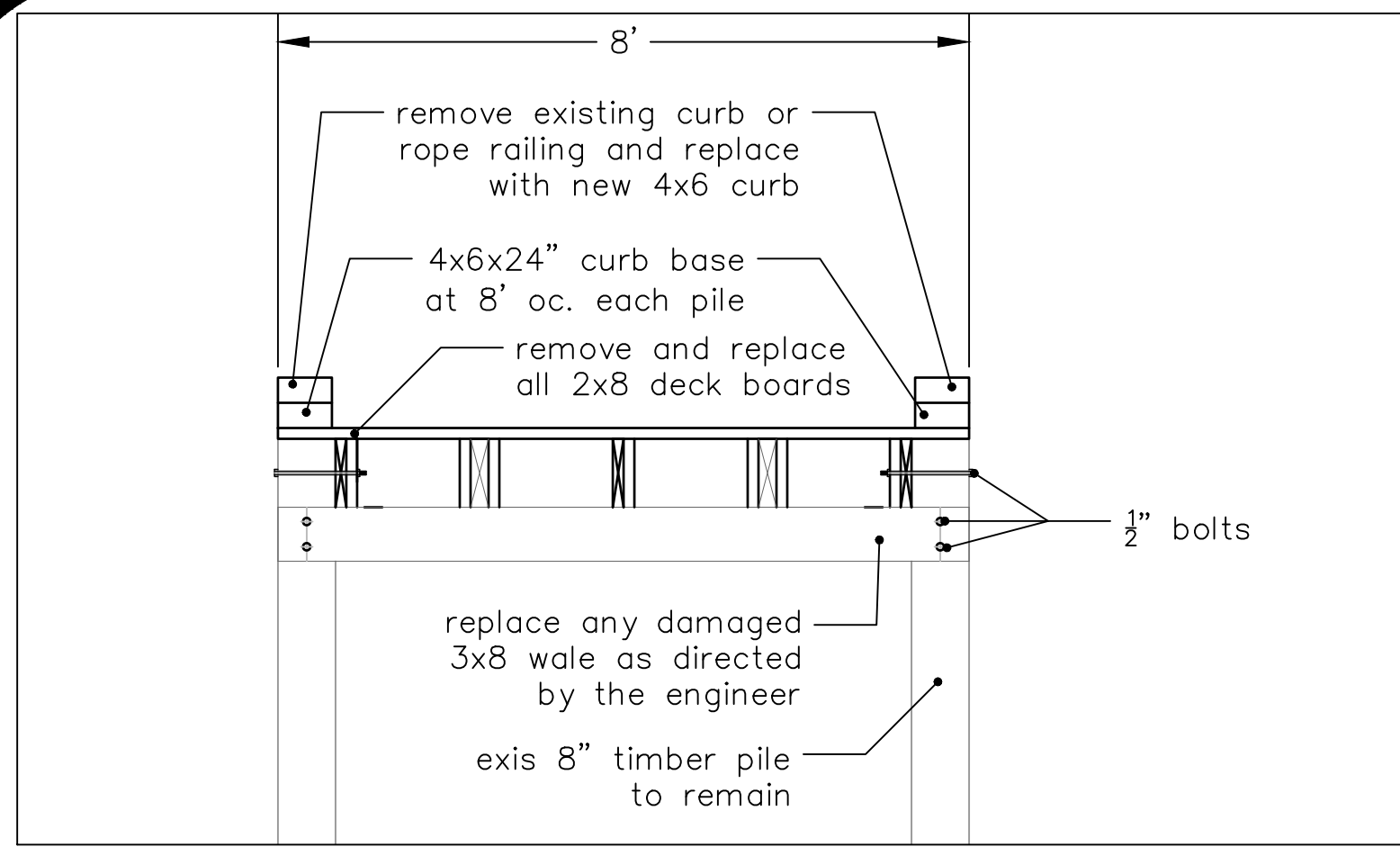

2 Section at 8' bridge  
Scale: 1/2" = 1'

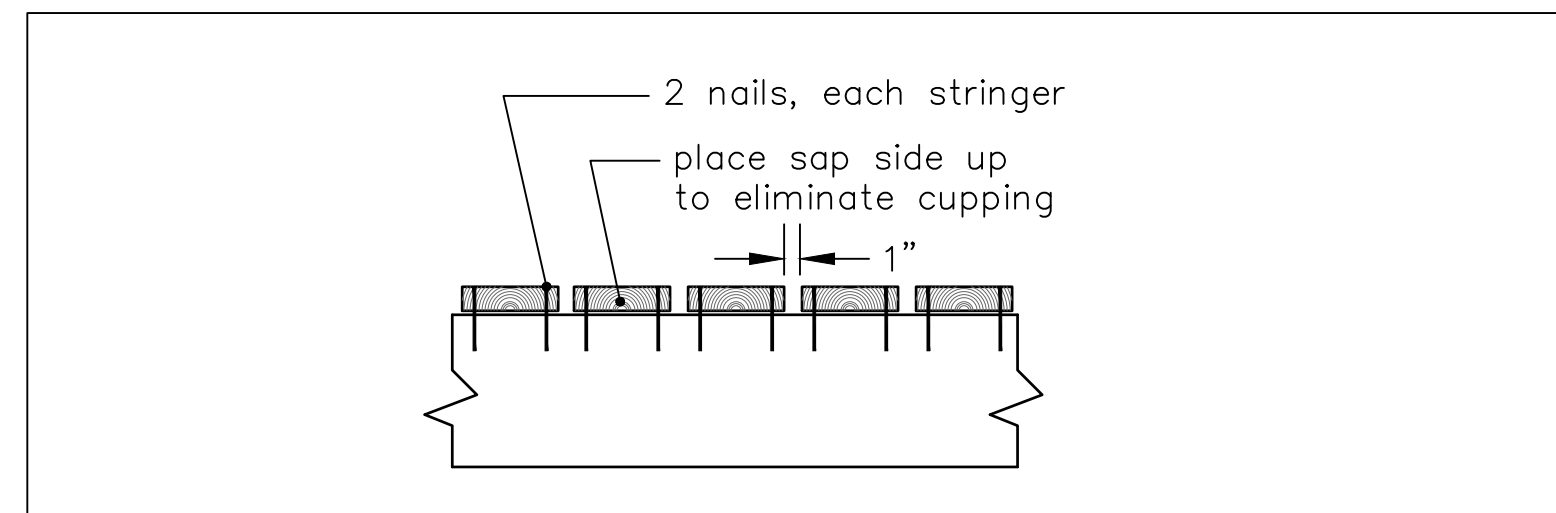

3 Deck Attachment Detail  
Scale: 1" = 1'

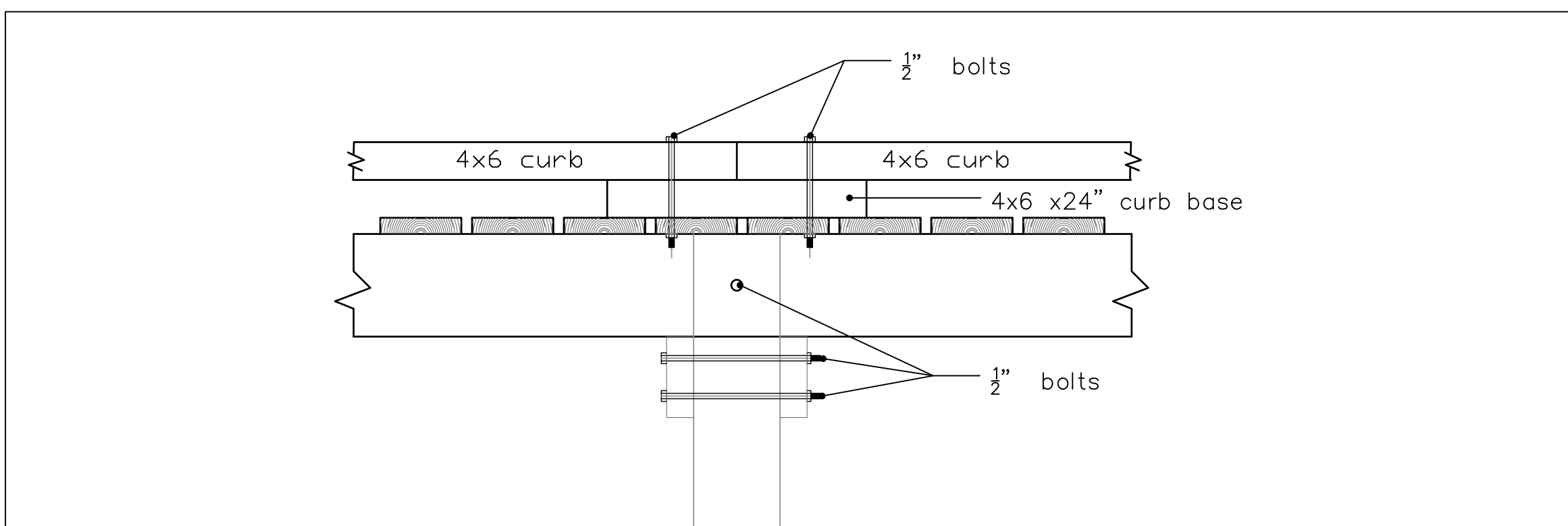

4 Section at pile  
Scale: 1" = 1'

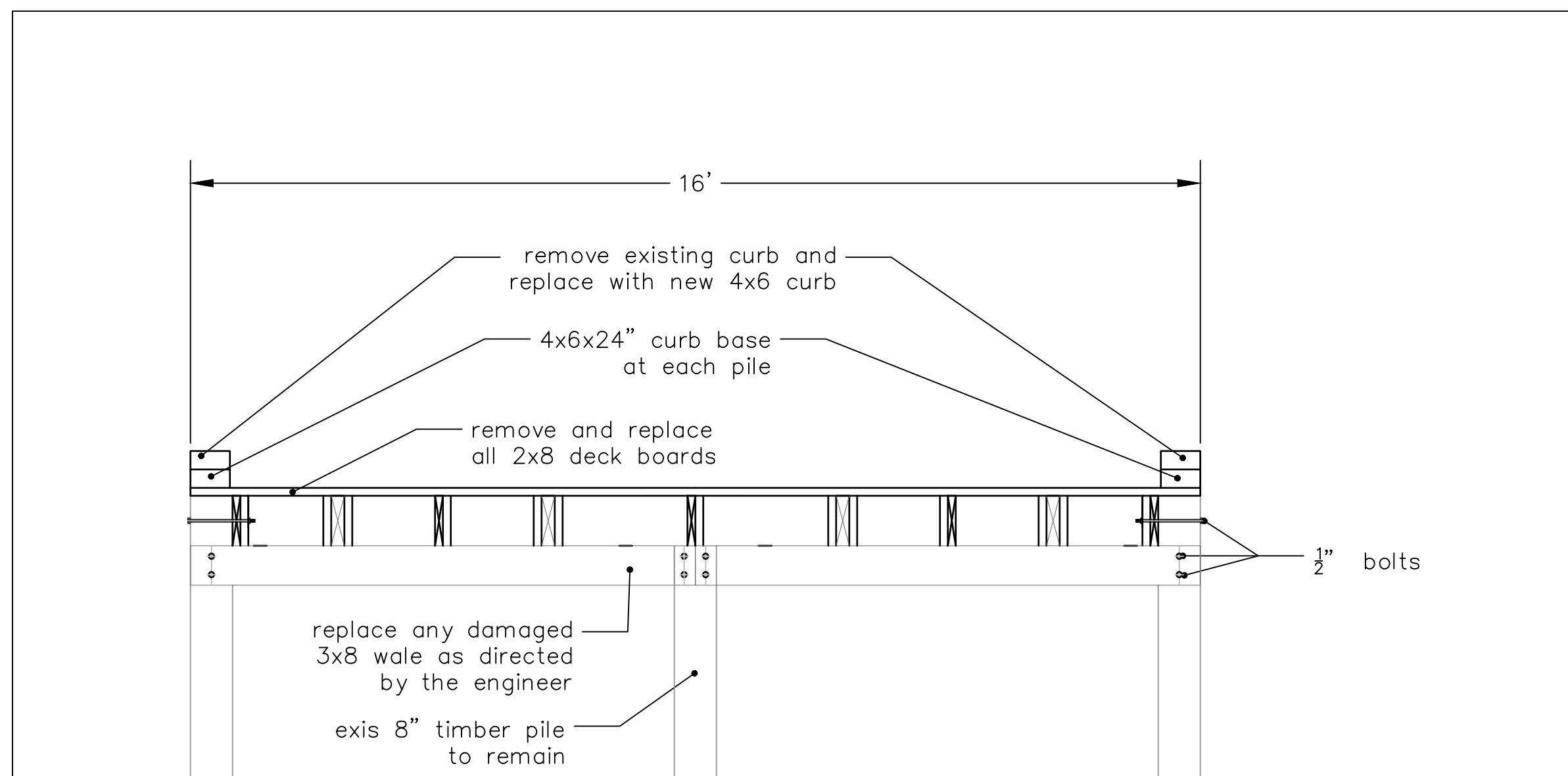

6 Section at 16' Birdge (CH)  
Scale: 1/2" = 1'

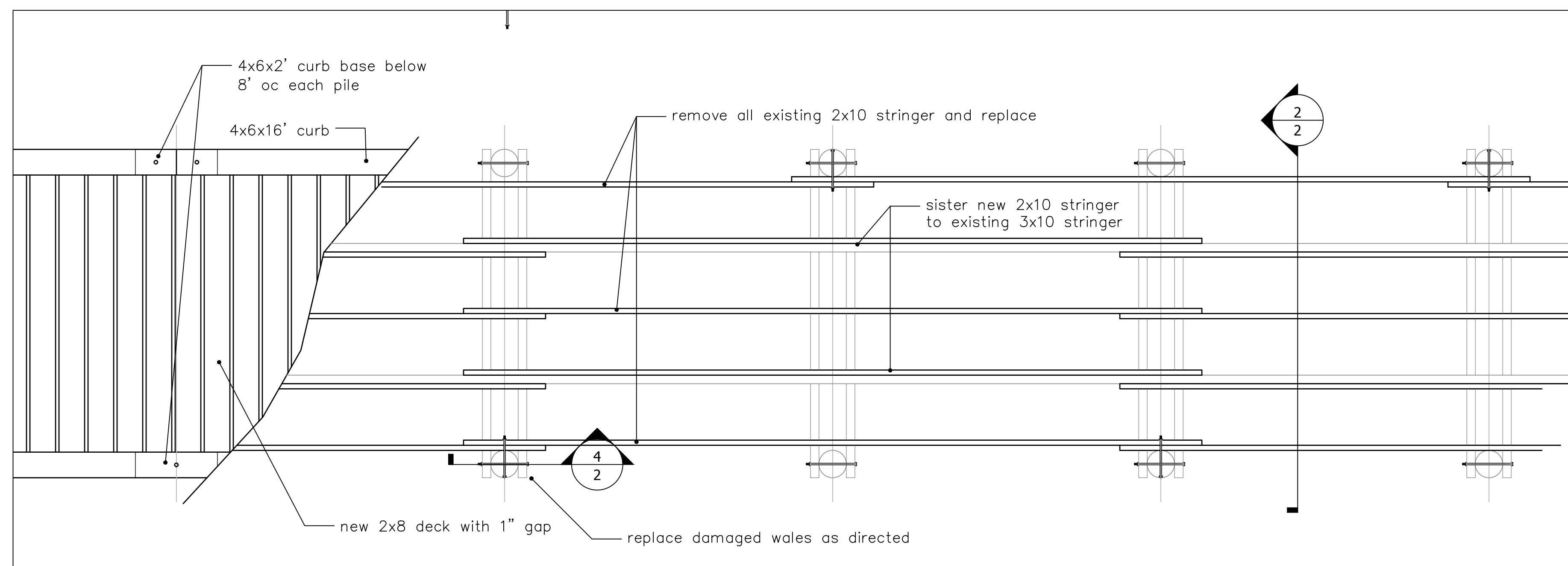

1 Plan Detail 8' Bridge  
Scale: 1/2" = 1'

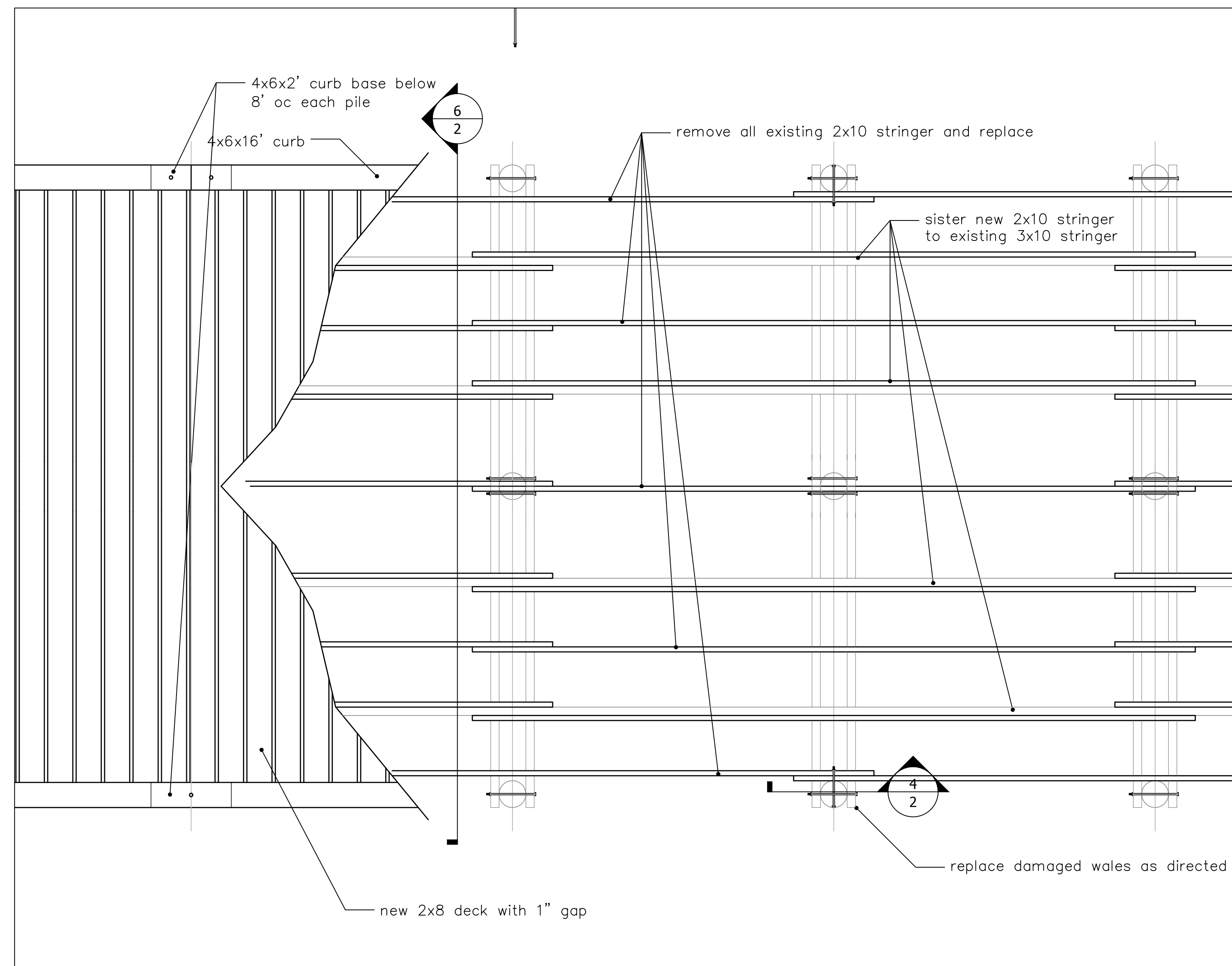

5 Plan Detail 16' bridge (CH)  
Scale: 1/2" = 1'

General Notes

No.	Revision/Issue	Date

Firm Name and Address  
**TOWN OF OCEAN CITY**  
 ENGINEERING DEPT,  
 301 BALTIMORE AVE.  
 OCEAN CITY, MD 21842  
 (410)289-8845

Project Name and Address  
**EAGLES LANDING GOLF**  
 COURSE  
 CART BRIDGE REPAIR  
 STRUCTURAL DETAILS  
 OCEAN CITY, MD 21842

Project  
**CART BRIDGE DE**  
 Date  
**7/29/2019**  
 Scale  
**AS SHOW**

Sheet  
**2**